

# АРХИТЕКТУРНАЯ ЭНЦИКЛОПЕДИЯ

ВТОРОЙ ПОЛОВИНЫ  
XIX века

## ДЕТАЛИ

ИЗБРАННЫЕ ТАБЛИЦЫ

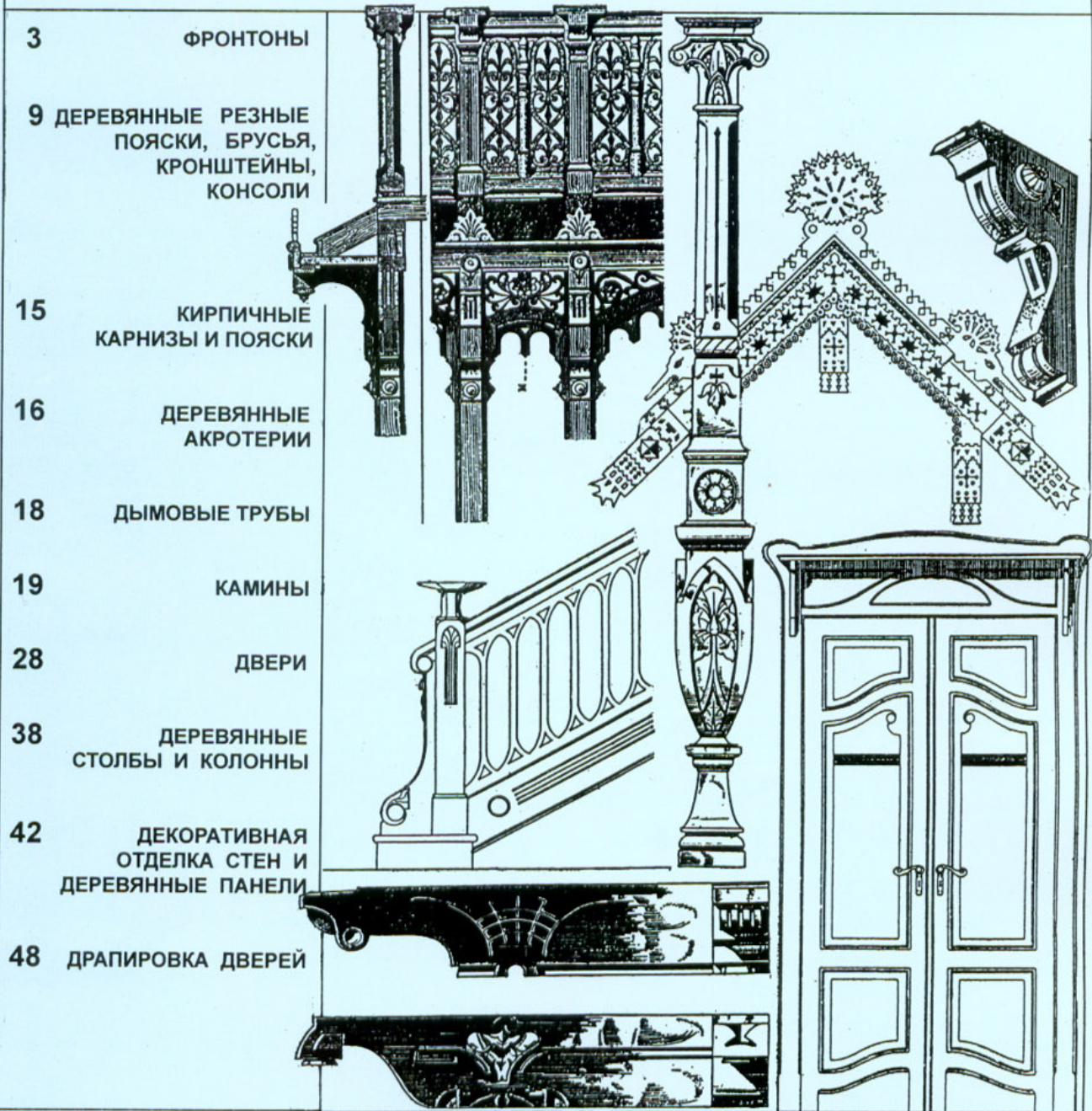

Г. В. БАРАНОВСКІЙ.

---

АРХИТЕКТУРНАЯ  
ЭНЦИКЛОПЕДІЯ  
ВТОРОЙ ПОЛОВИНЫ  
XIX ВѢКА

Изданіе редакціи журнала «Строитель».

С.-ПЕТЕРБУРГЪ.

Типографія журнала «Строитель», Фонтанка, 66.  
1904.

Г.В.Барановский

# АРХИТЕКТУРНАЯ ЭНЦИКЛОПЕДИЯ

ВТОРОЙ ПОЛОВИНЫ

**XIX** века

---

## ДЕТАЛИ

ИЗБРАННЫЕ ТАБЛИЦЫ

ВЫПУСК 2



Арх. Н. Набоковъ.



Арх. Н. Набоковъ.

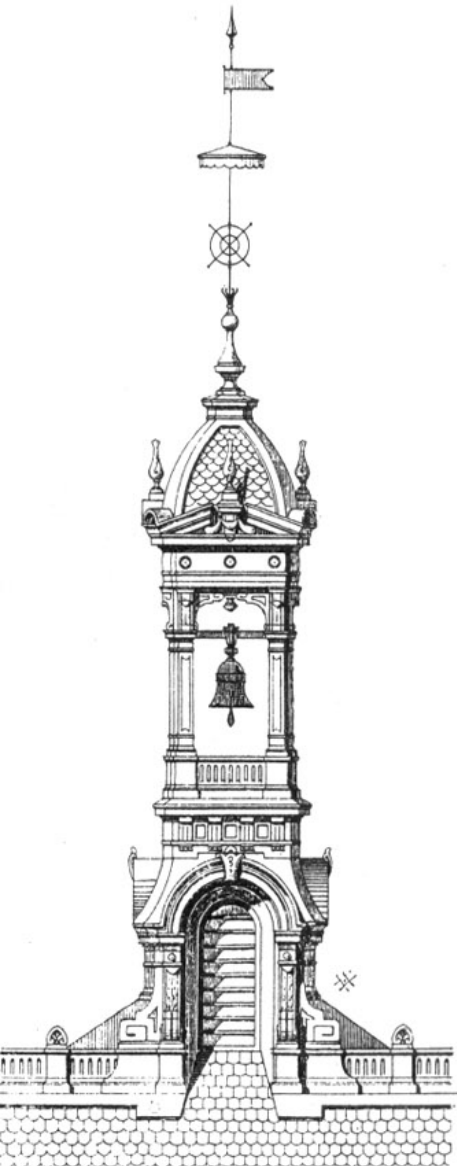

Арх. Н. Набоковъ.

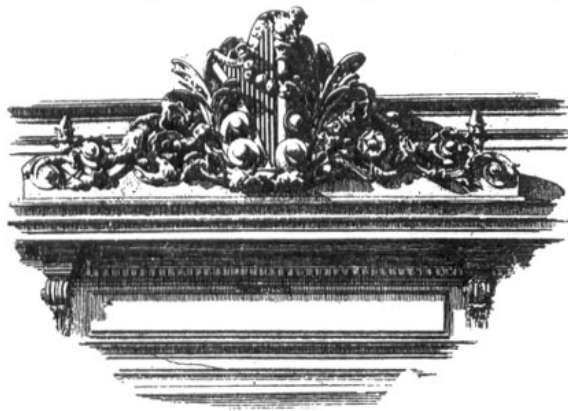

Здание оперы въ Ниццѣ.

Арх. André.

Всем. Выст. 1900 г. въ Парижѣ.  
Марсово поле.

Арх. V. Blavette.





Детали Царскаго павильона на Всероссийской Выставкѣ 1896 г. въ Н.-Новгородѣ.



Домикъ въ Гёсапр (Франція).  
Арх. Fréret.

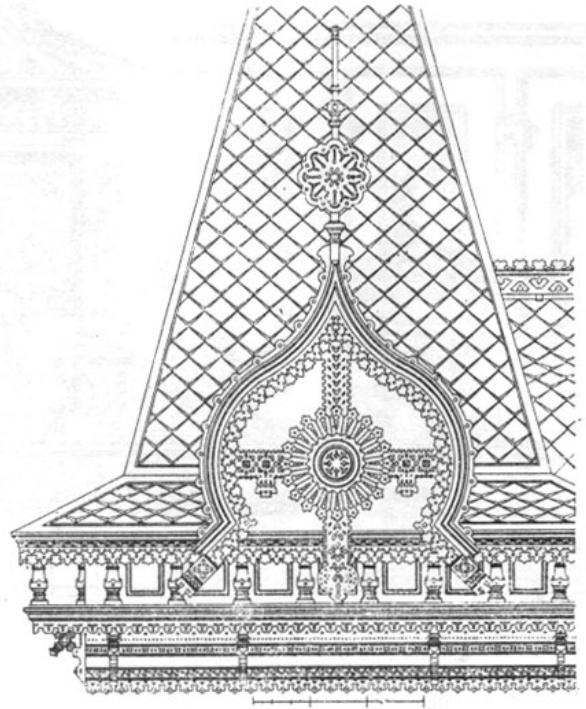

Фронтонъ башни.  
Проф. Арх. А. Н. Померанцевъ.

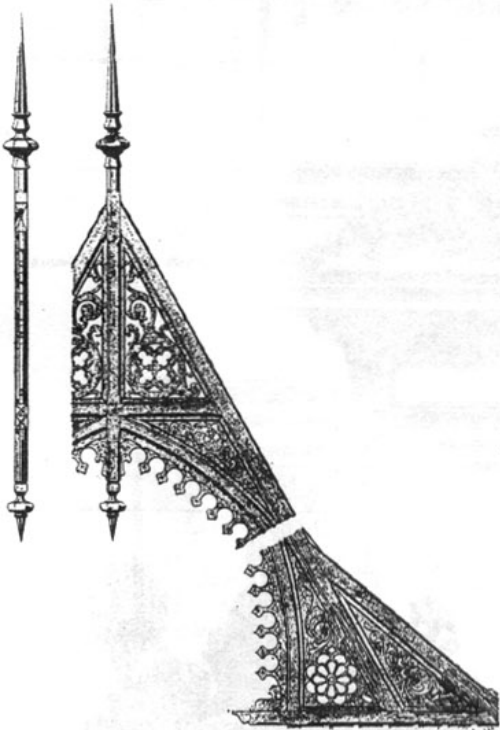

Домикъ въ Гёсапр (Франція).  
Арх. Fréret.

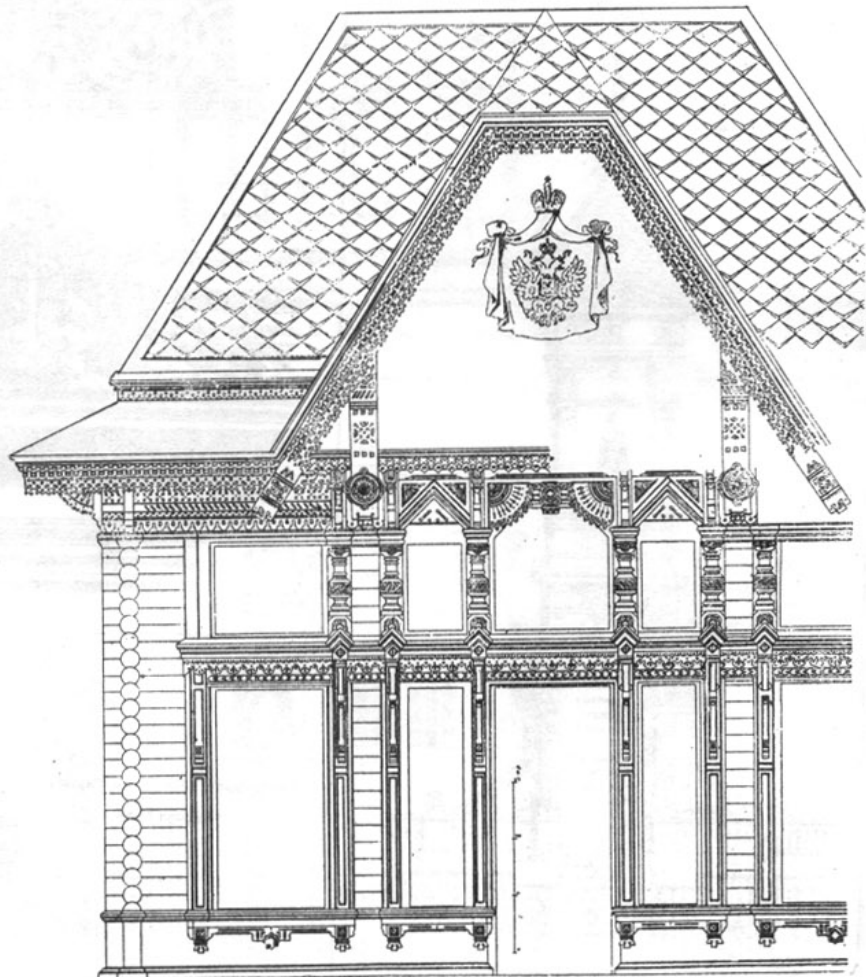

Фронтонъ окна.

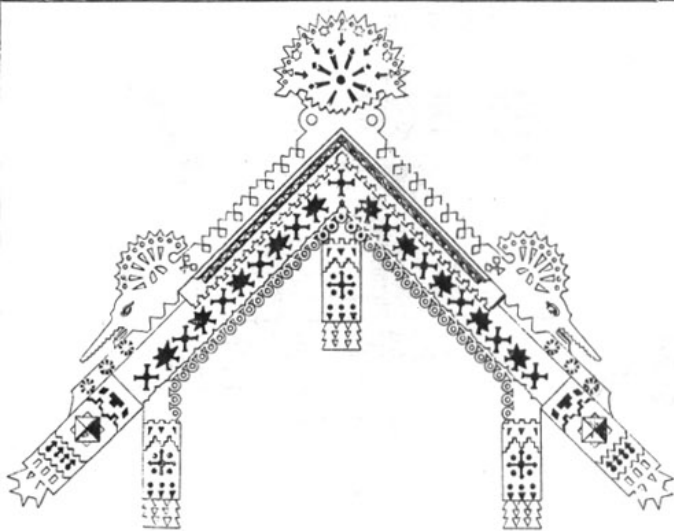

Фронтонъ рѣзной.

Анад. Арх. Гартманъ.

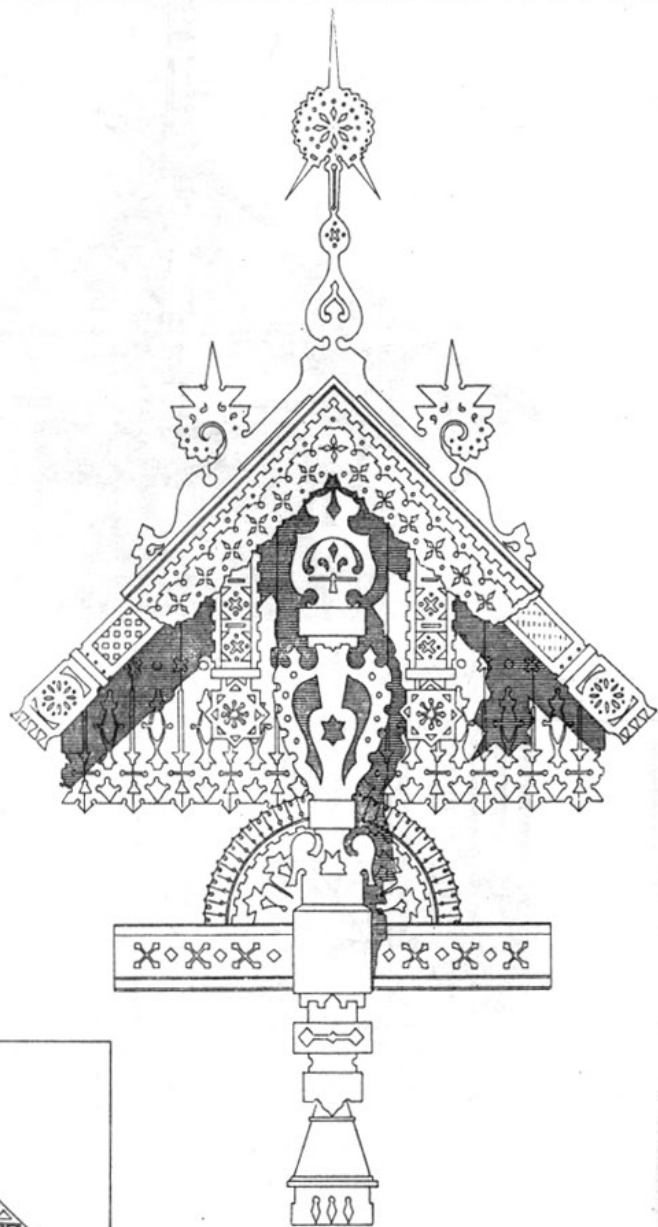

Арх. Ф. Харламовъ.

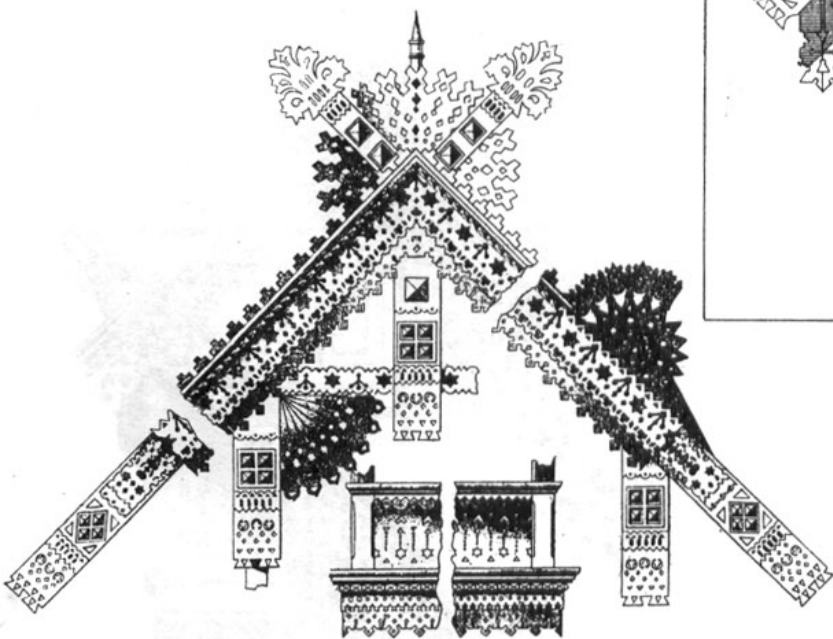

Анад. Арх. Гартманъ.

Детали фронтона.

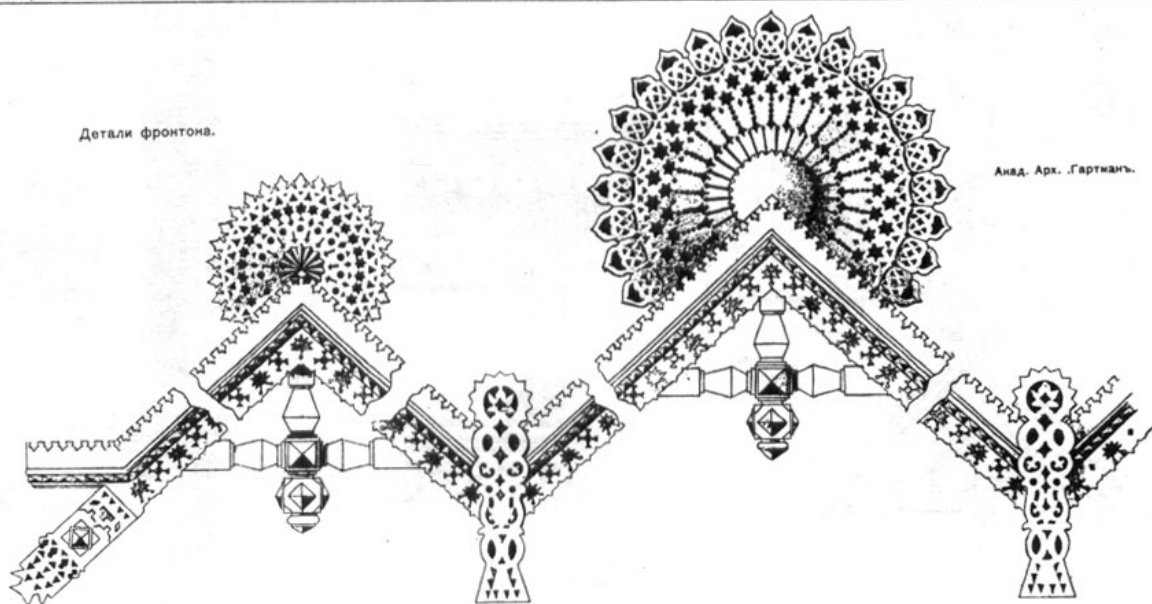

Анад. Арх. Гартманъ.

ФРОНТОНЫ

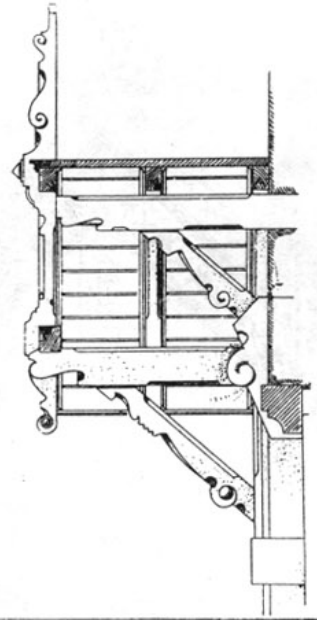
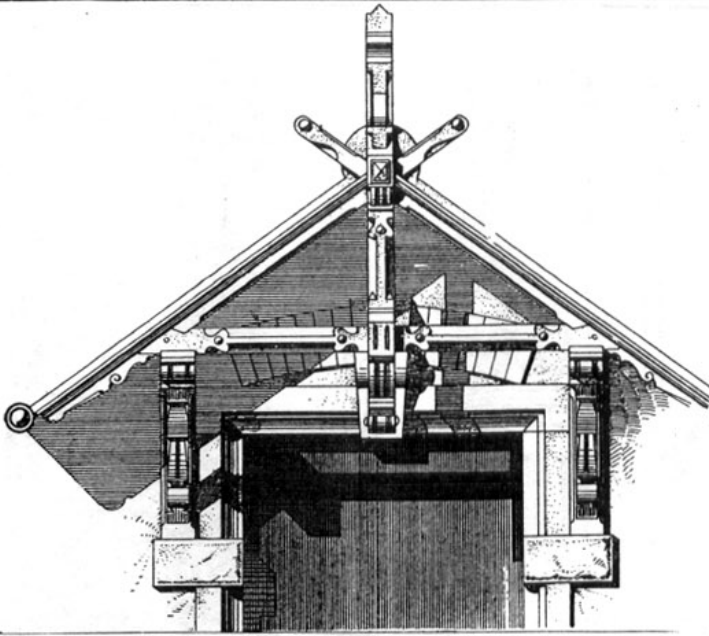

Мотивы деревянных фронтоновъ.

Frontons en bois.

Höizerne Giebel.

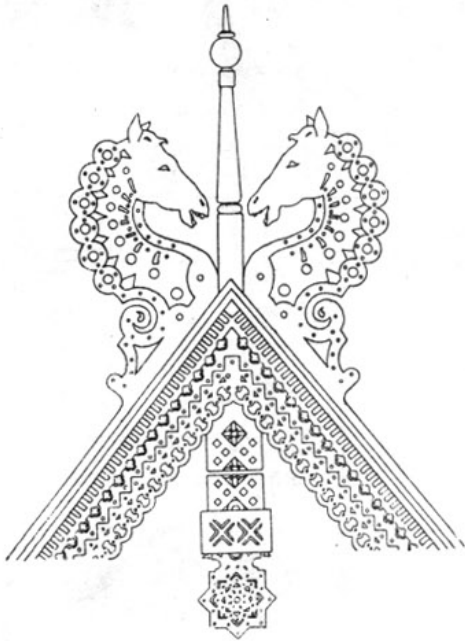

Арх. Ропетъ.

Дача Бутурлина въ С.-Петербургъ.

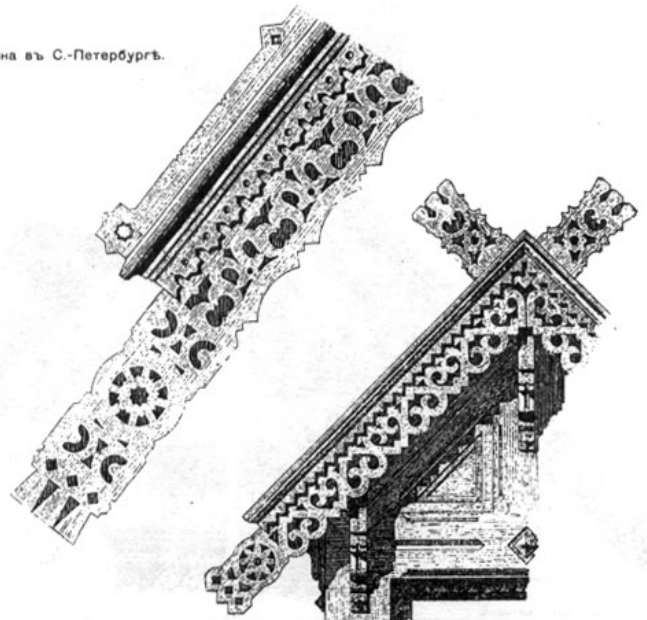

Арх. В. И. Соболицкинъ.

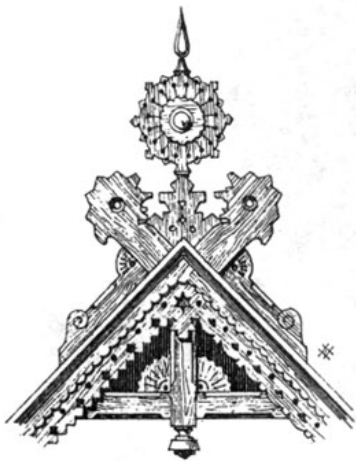

Арх. Н. Набоковъ.



# ФРОНТОНЫ

Вѣна. (Heugasse № 26). Вѣнчанія крышъ. Арх. Destailleur.

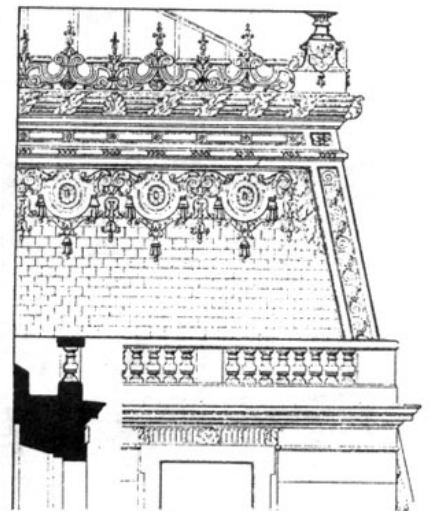
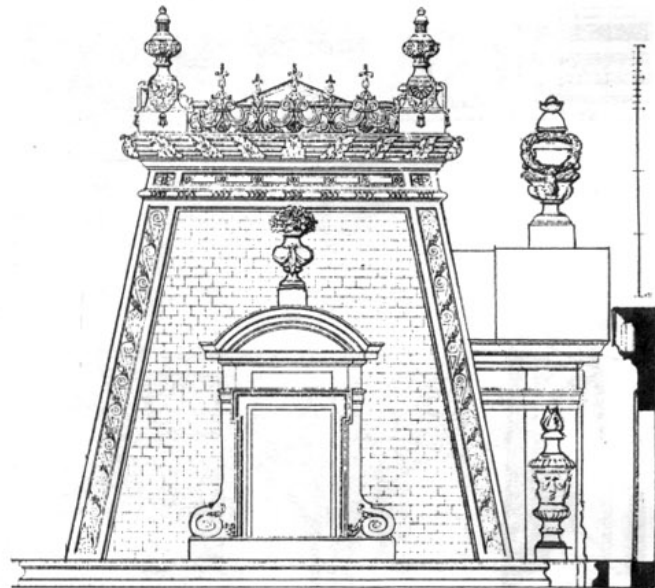
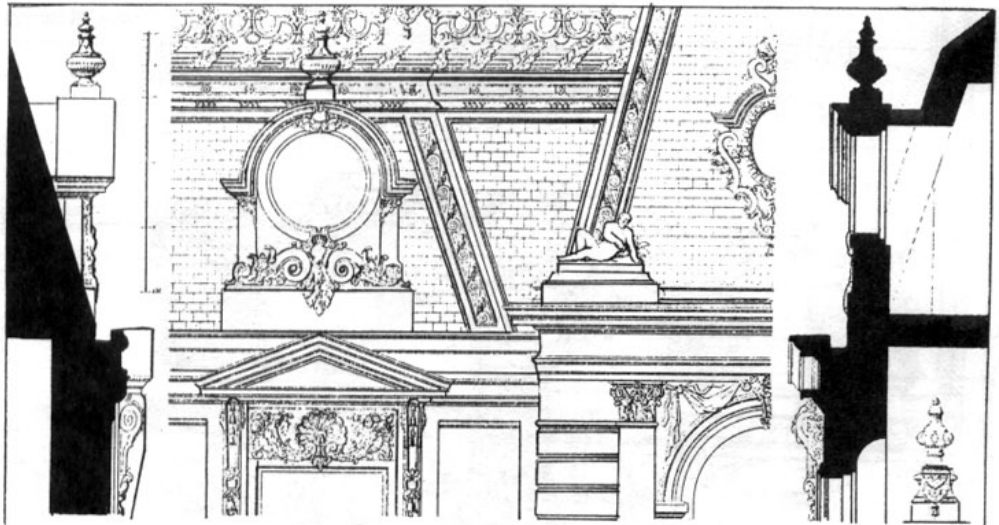

Всероссійская  
Художеств.-Промышлен.  
выставка 1896 г.  
въ Нижнемъ-Новгородѣ.

Башни  
Императорскаго  
павильона.  
Арх. Виррихъ.

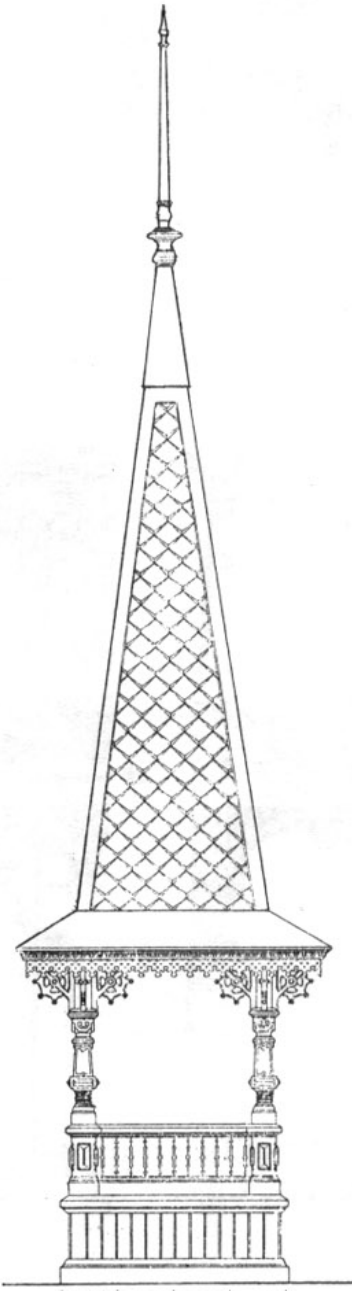
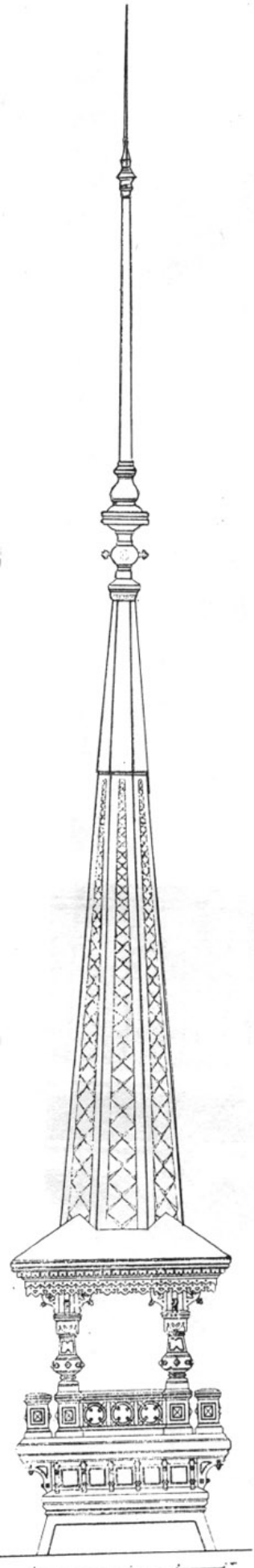



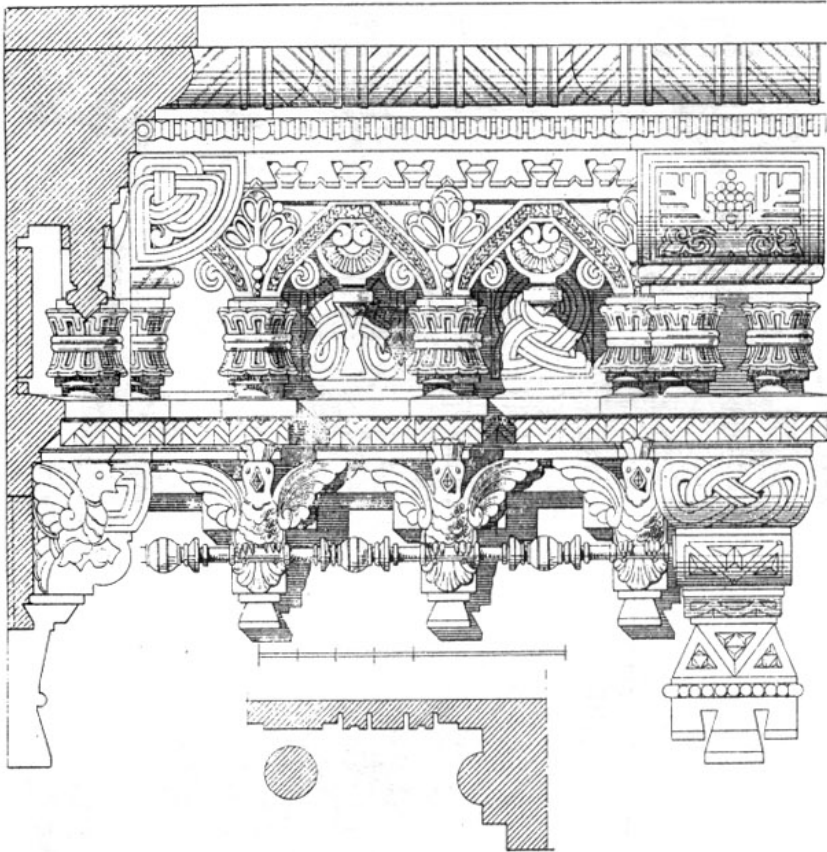

Деревянный карнизъ.

Арх. Ропатъ (Спб.).

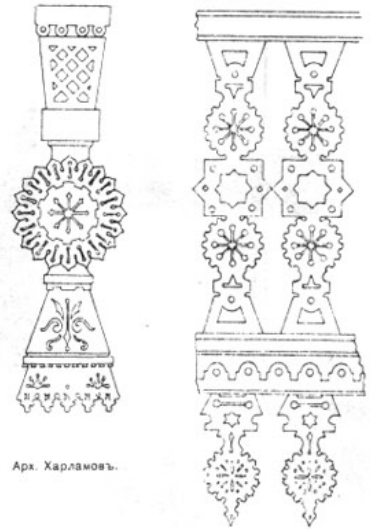

Арх. Харламовъ.



Арх. Харламовъ.

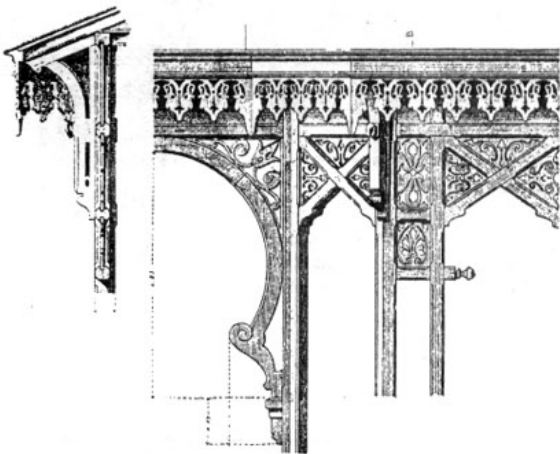

Парижъ. Всем. Выст. 1867 г.

Арх. Waaser.

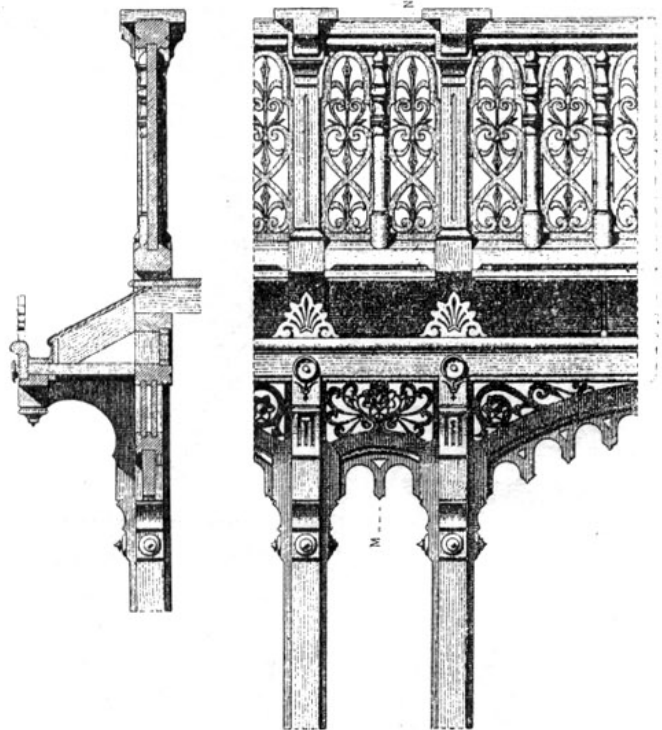

Парижъ. Всем. Выст. 1867 г.

Арх. Haret.

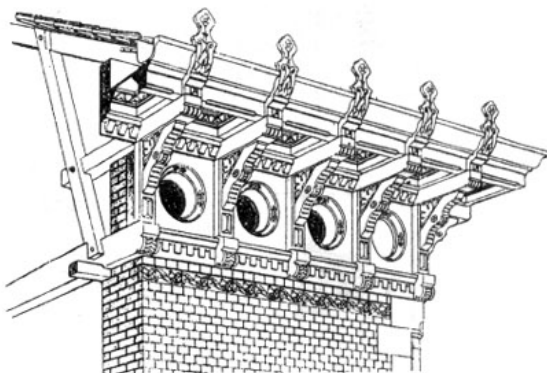

Арх. Prof. C. Dollinger.

Мотивы деревянных резных поясков  
по В. Liebold'y.

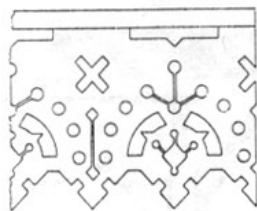
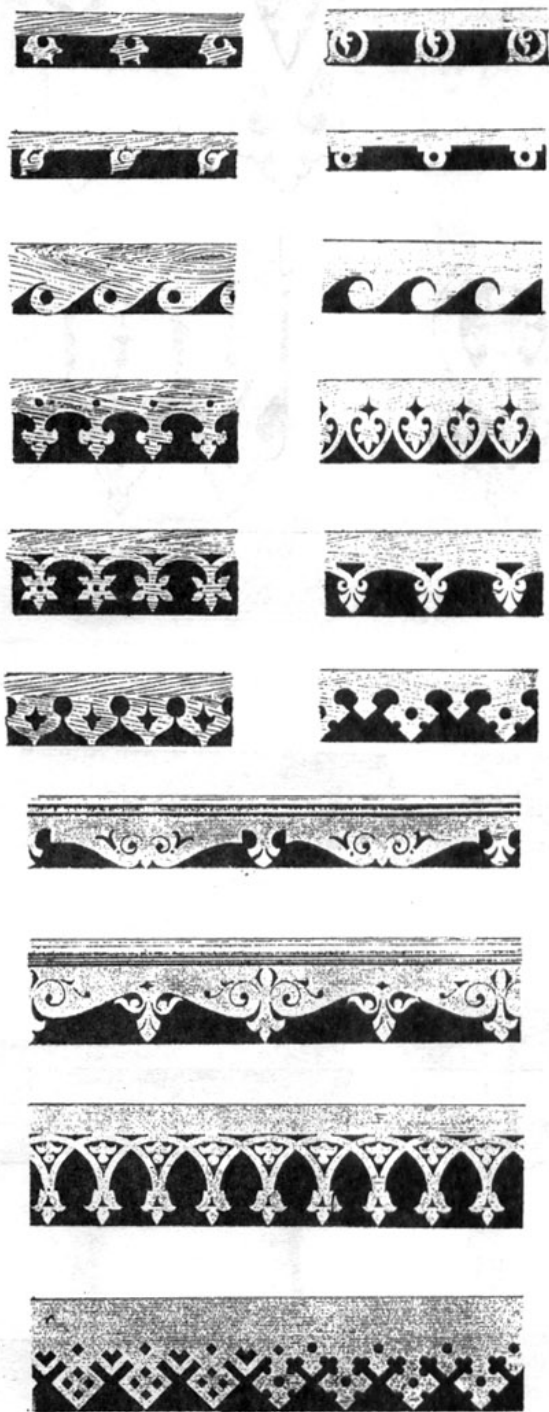

Арх. Харламовъ.

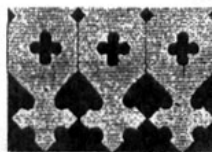

Театръ въ Павловскъ.  
Проф. Арх. Н. Л. Бенуа.

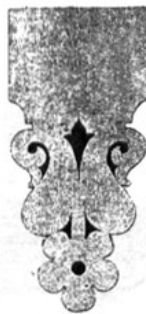
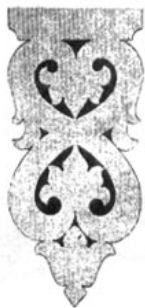
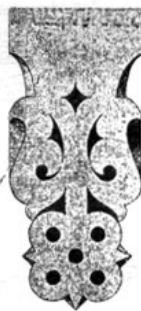
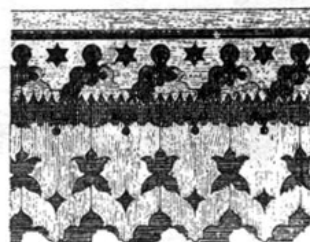
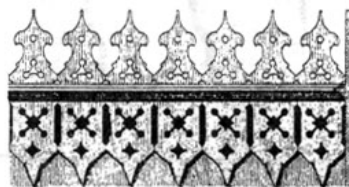

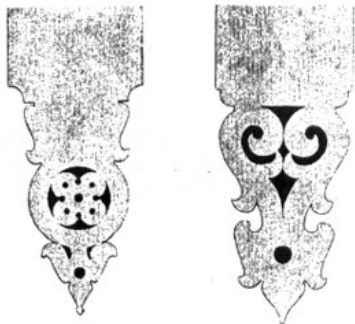

Мотивы деревянных порѣзковъ для карнизовъ.

По В. Liebold'у.

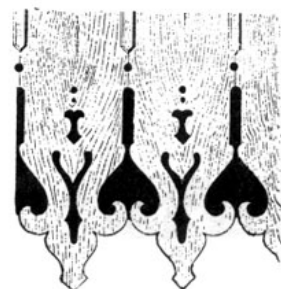
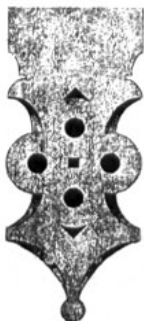
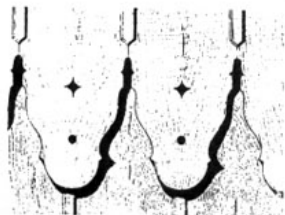
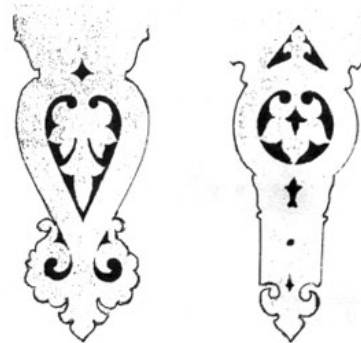

Мотивы обработки концовъ брусьевъ по Krauth'у и Meyer'у.

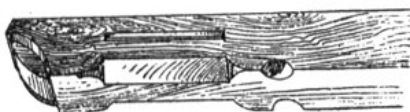
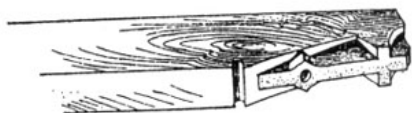
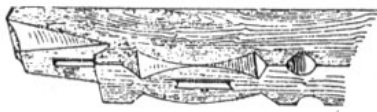
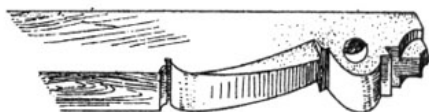
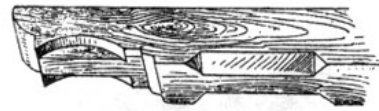
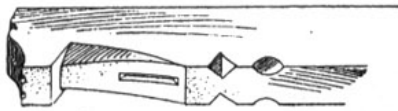
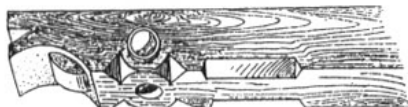
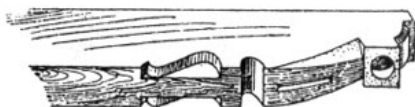

Мотивы обработки концов брусьев по Krauth'y и Meyer'y.

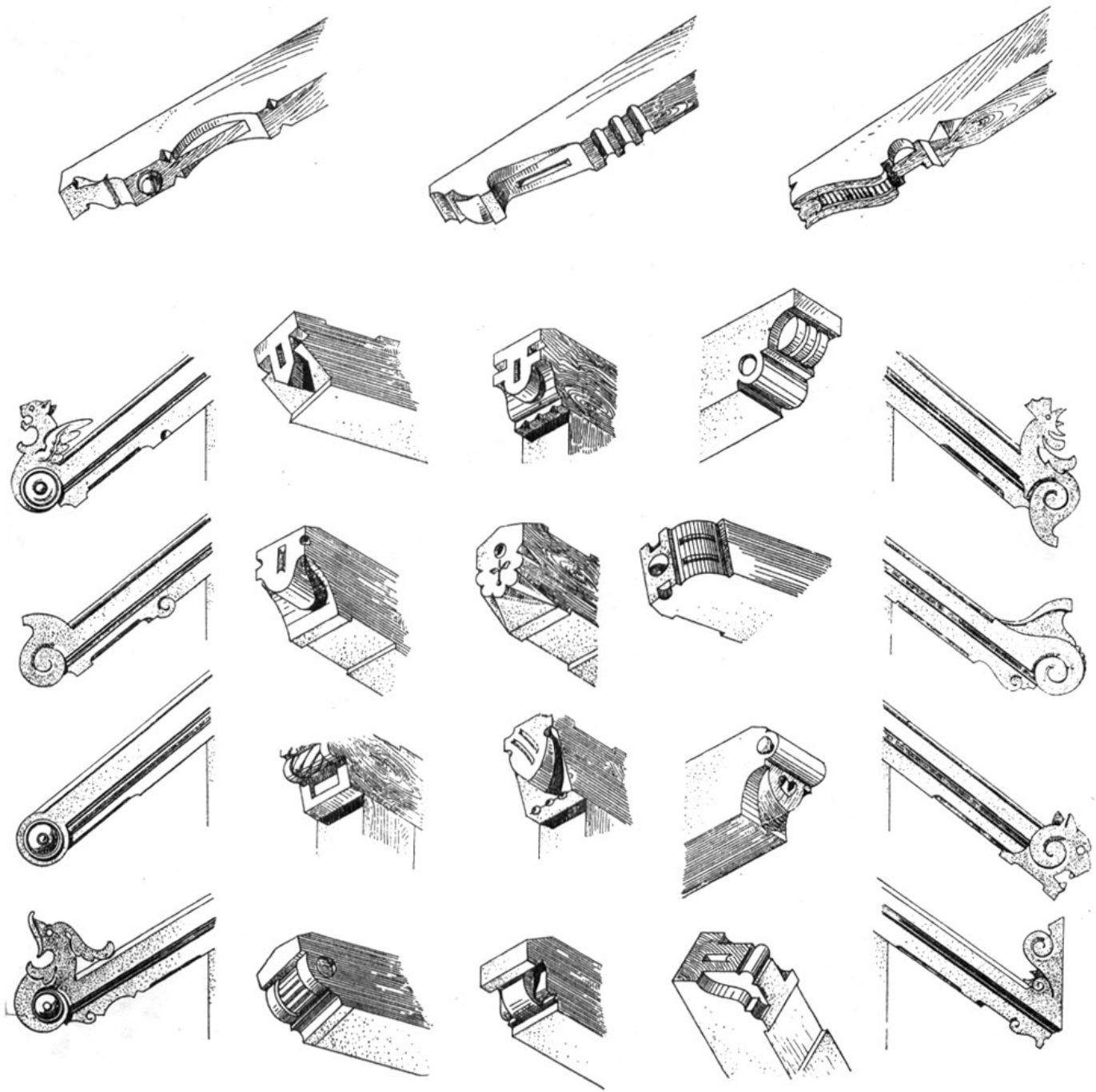

Мотивы обработки концов брусьев.

Richard von Dorschfeldt.

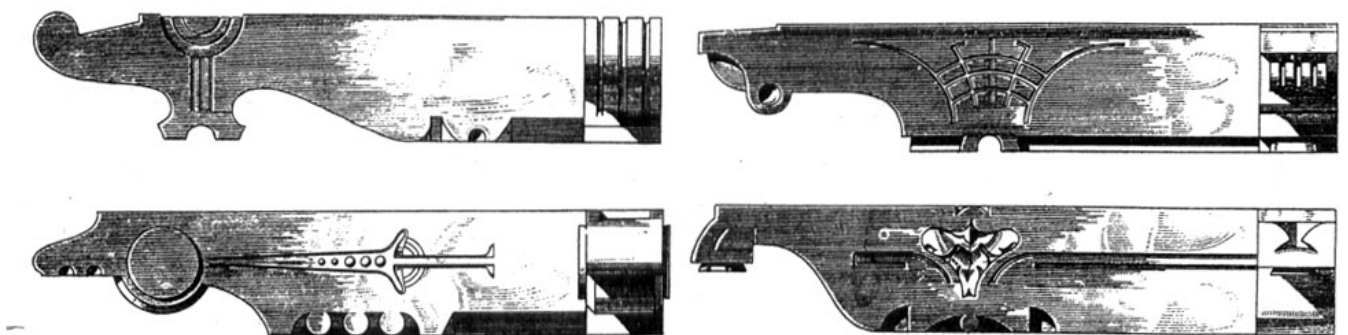



Мотивы деревянных кронштейнов. По В. Liebold'y.

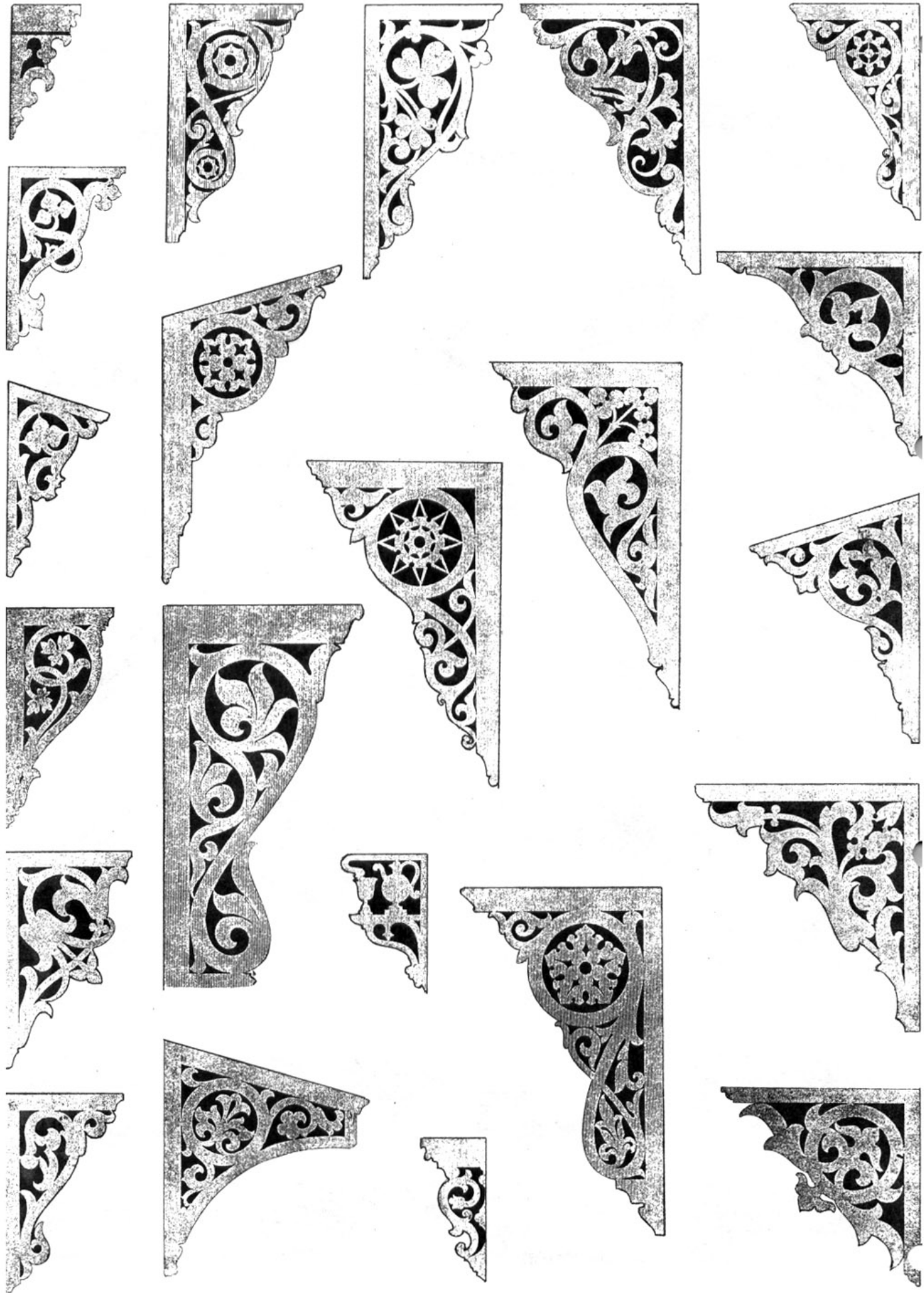

# ДЕРЕВЯННЫЕ РЕЗНЫЕ ПОЯСКИ, БРУСЬЯ, КРОНШТЕЙНЫ, КОНСОЛИ

Мотивы деревянных консолей.

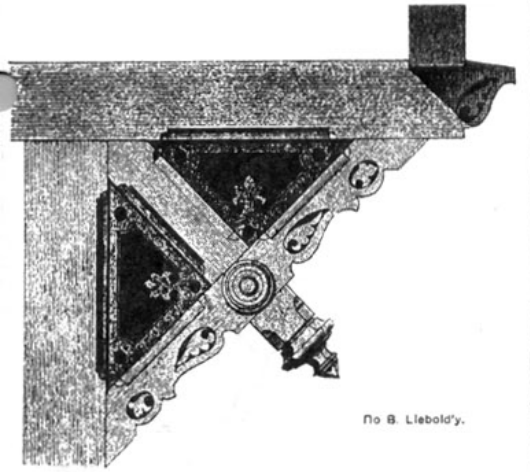

По В. Liebold'y.

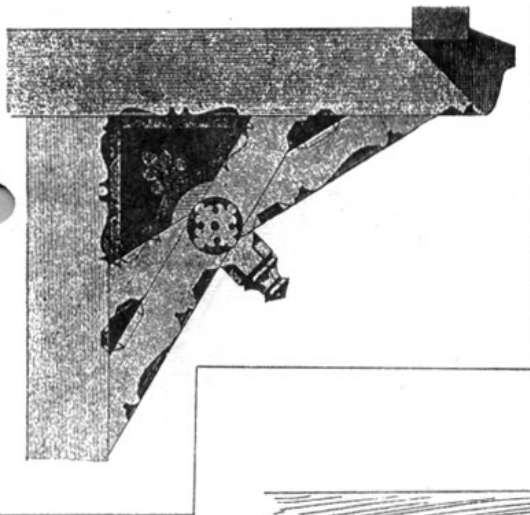

Мотивы деревянных консолей.

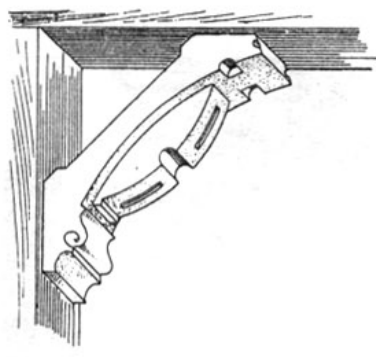

По Krauth & Meyer'y.

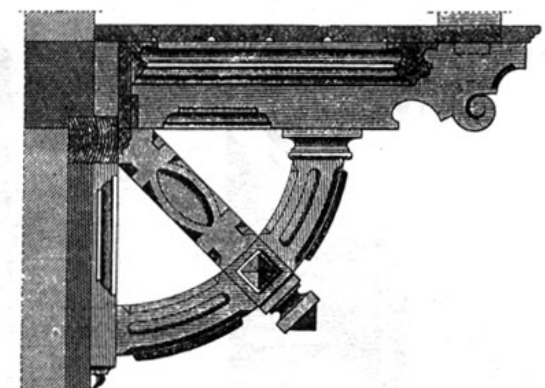
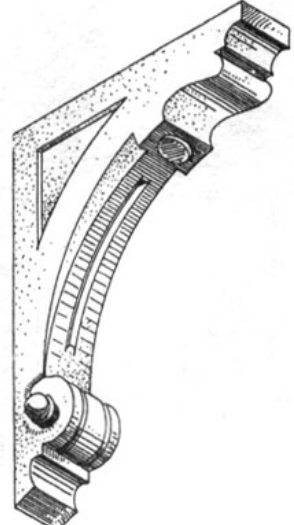
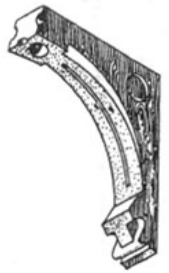
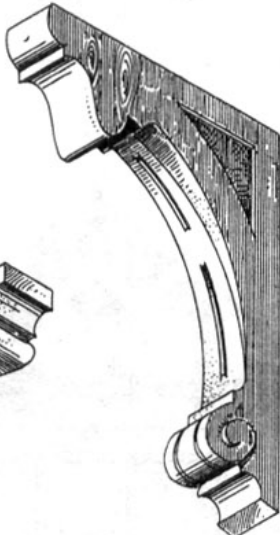
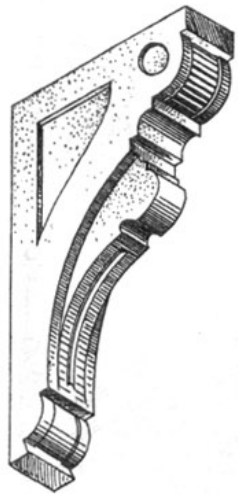
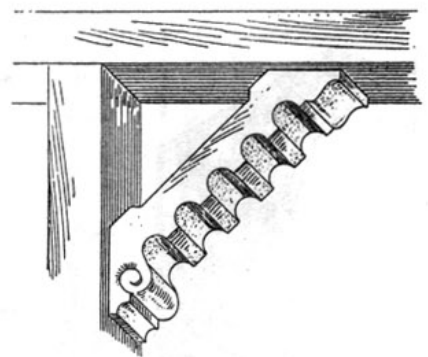
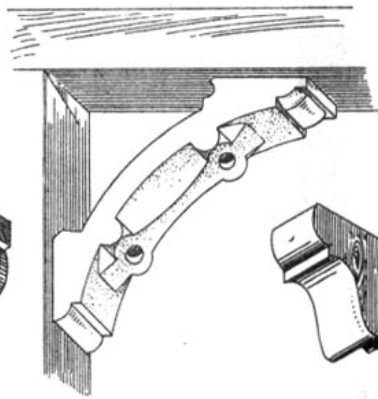
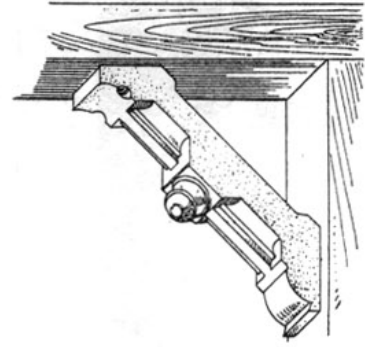
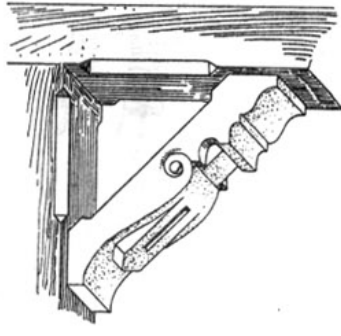
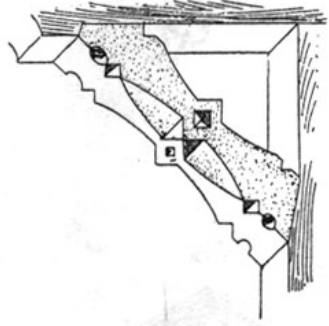
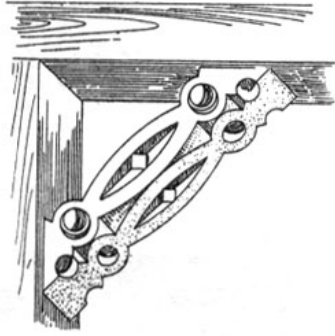
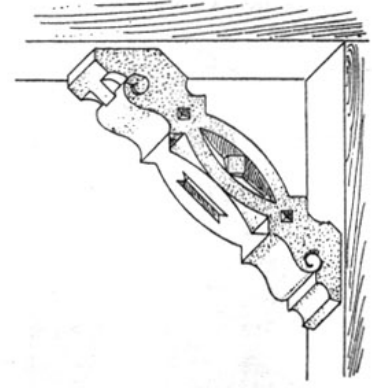

Мотивы деревянных консолей.  
По Krauth'y & Meyer'y.

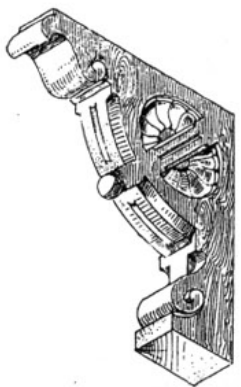
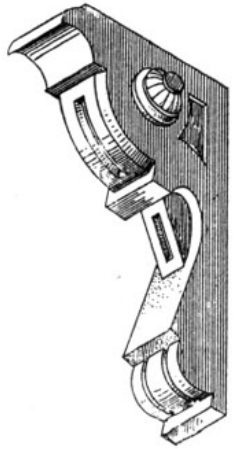
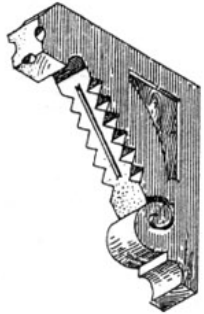
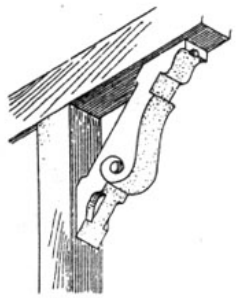

Мотивы деревянных консолей. По Dorschfeldt'y.

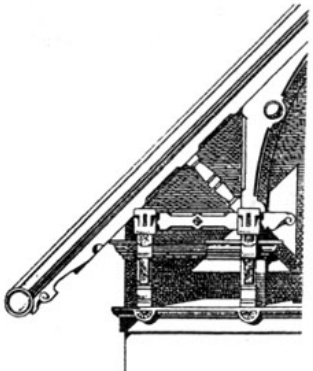
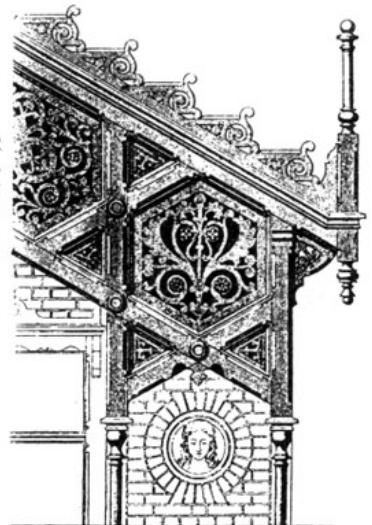
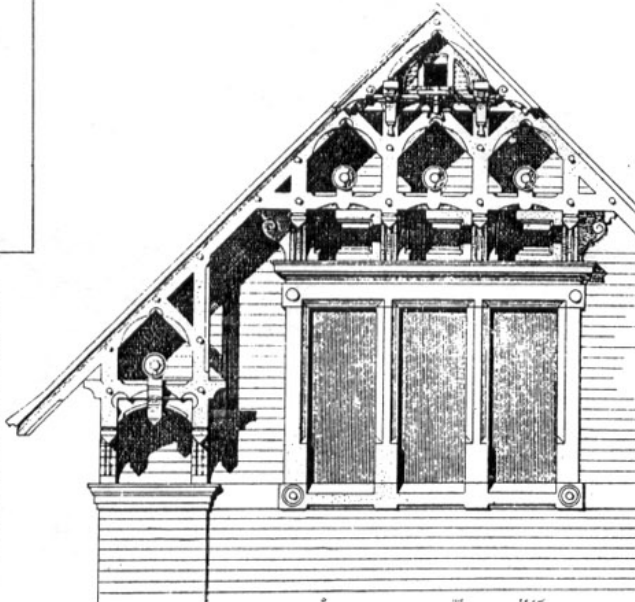
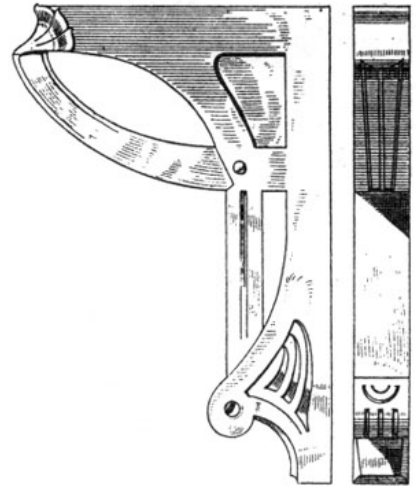
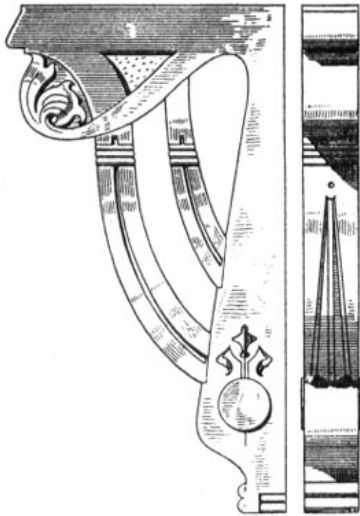
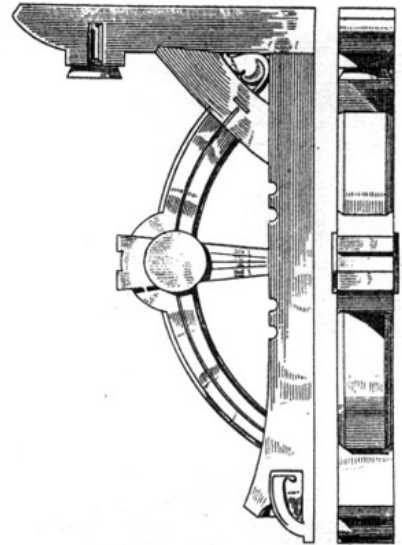
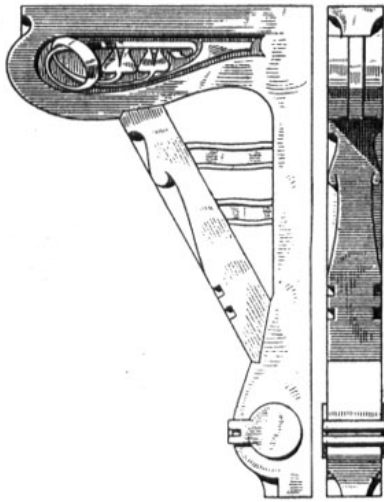

# КИРПИЧНЫЕ КАРНИЗЫ И ПОЯСКИ

Мотивы кирпичных карнизов и поясков. По В. Liebold'y.

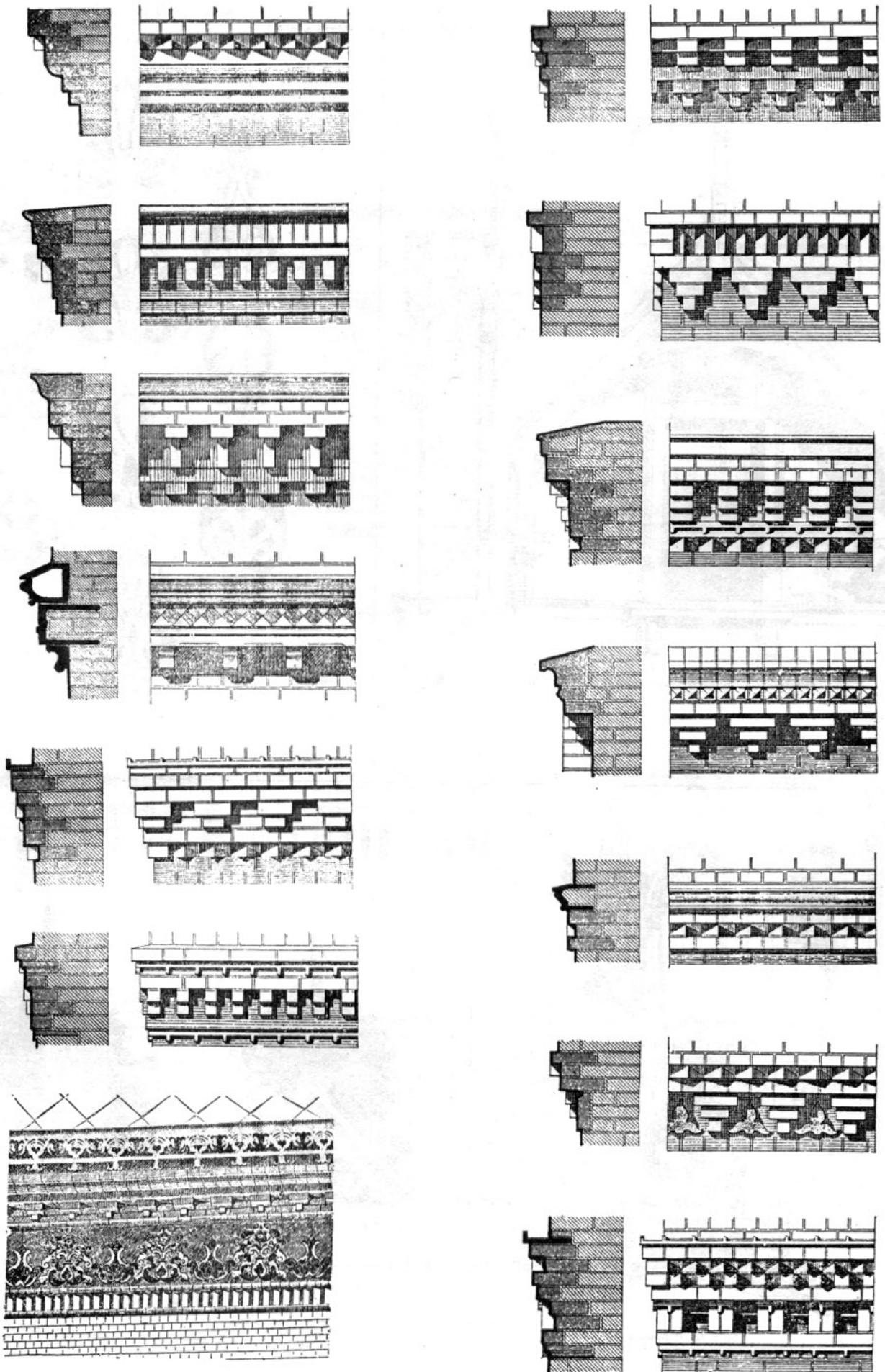



Мотивы деревянных акротеровъ.

Acrotères en bois.

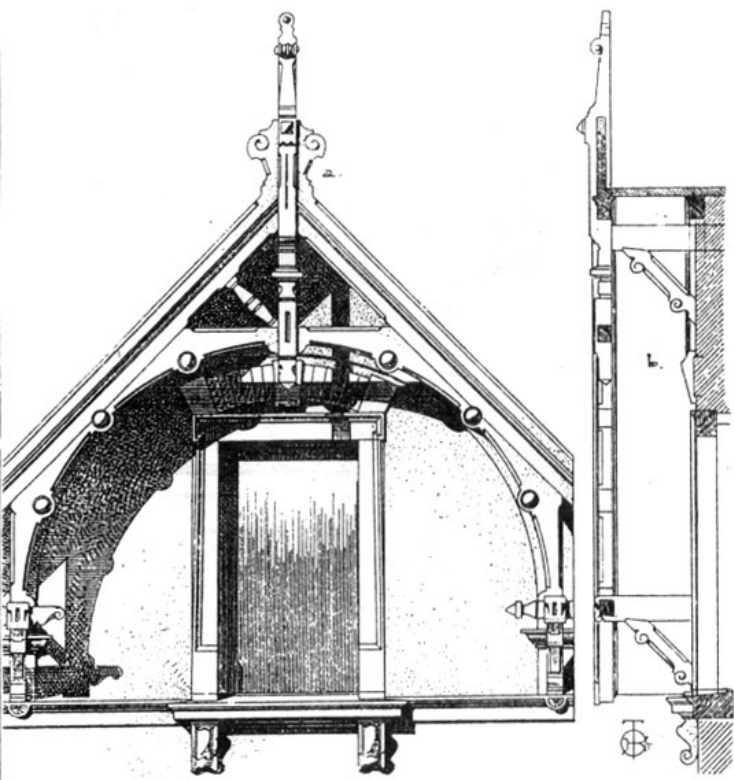

Арх. В. Liebold.

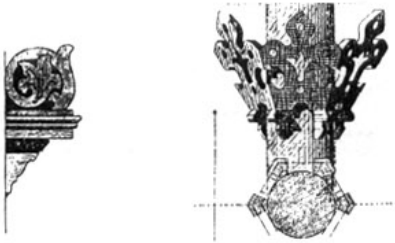

Театръ въ Павловскъ.



Проф. Арх. Н. Л. Бенуа.

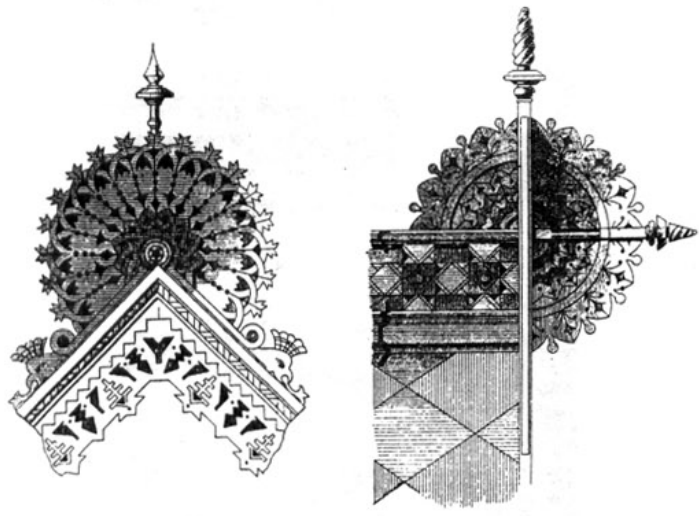

Арх. Кузьминъ.

# ДЕРЕВЯННЫЕ АКРОТЕРИИ

Деревянные акротеры.

Арх. R. Dorschfeldt.

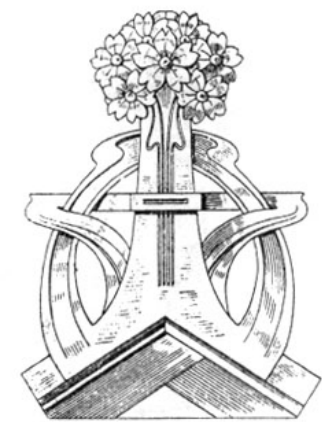
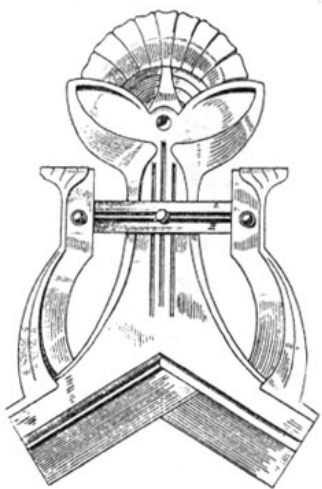

Деревянные акротеры.

Арх. Krauth & Meyer.

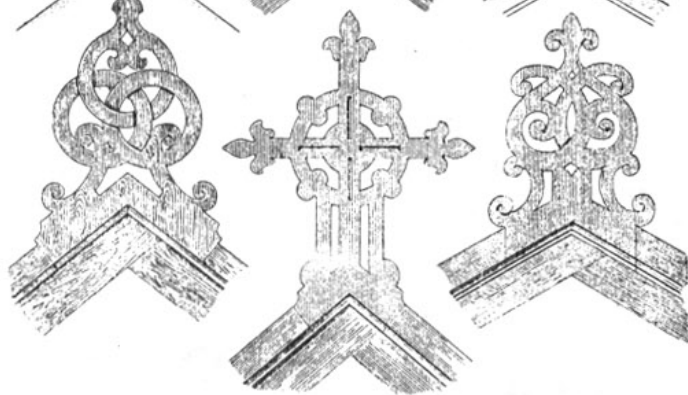
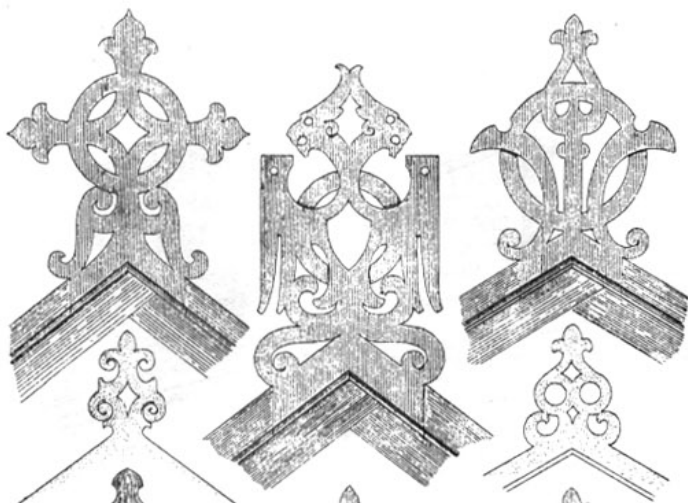

Деревянные акротеры.

Арх. R. Dorschfeldt.

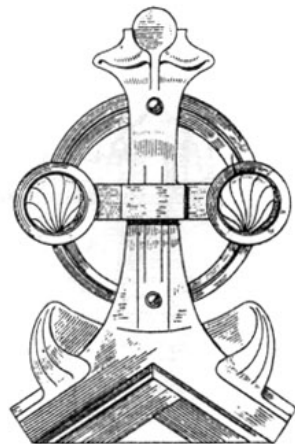

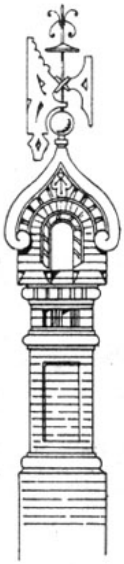

Арх. Кузьминъ.

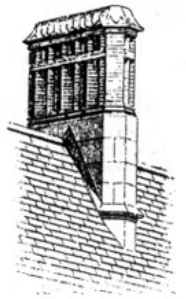
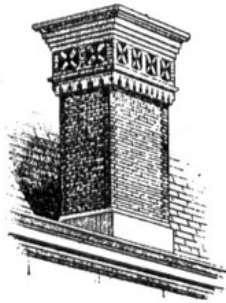
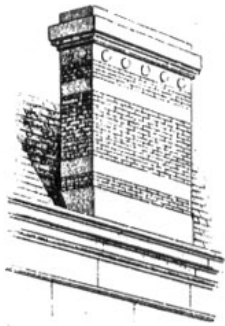

Мотивы трубъ. По Севаг Daly.

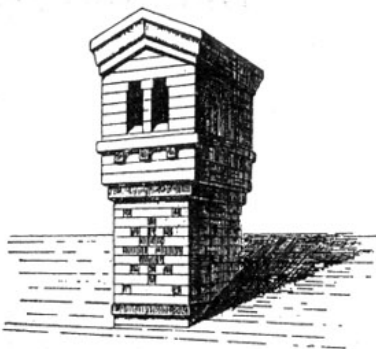
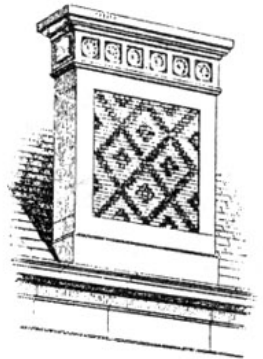
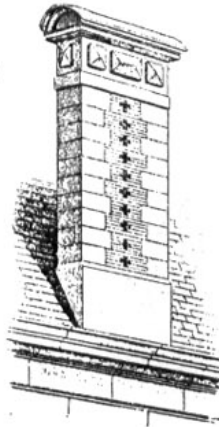
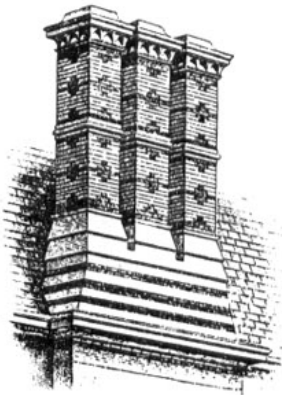
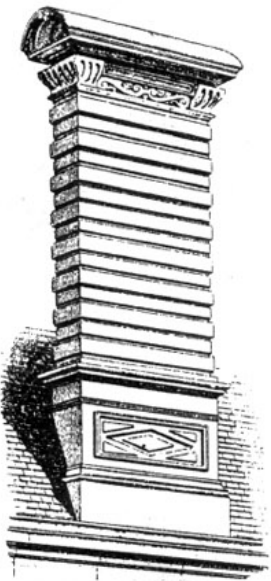

Арх. Monnier.

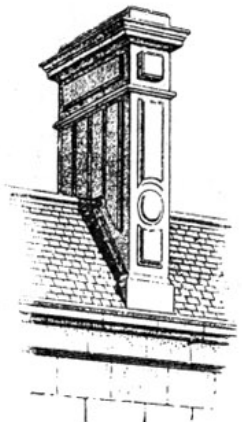
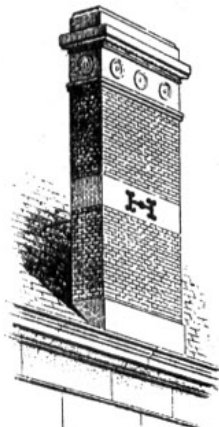
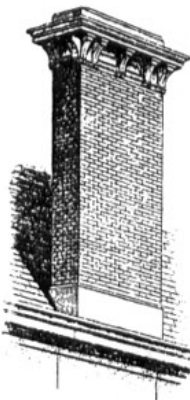

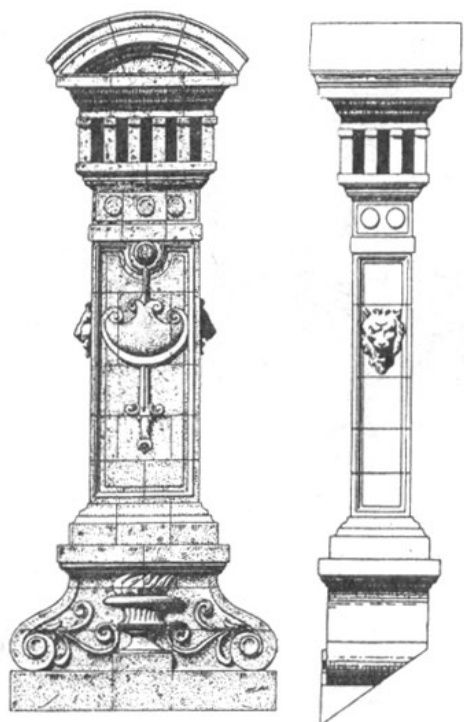

Арх. Duc (Paris).



Арх. Questel. (Paris)

Мотивы трубъ.

Арх. R. Oréans.

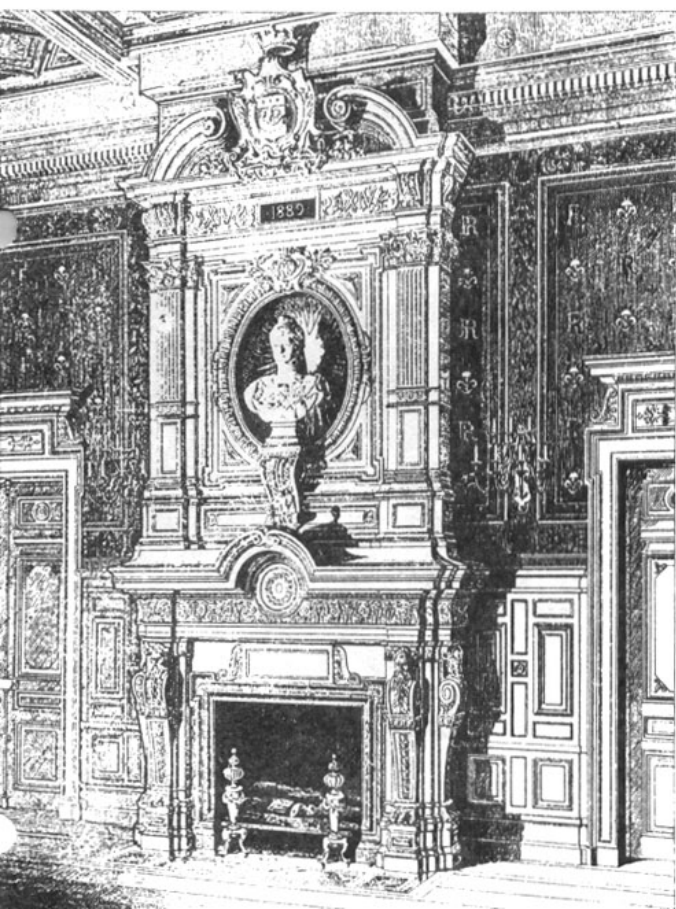
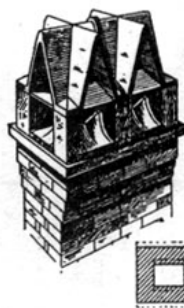
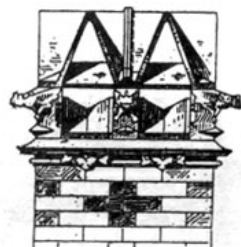

Парижъ. Зд. мэри XVI-го округа. Каминъ въ залѣ.

Арх. Auburtin.

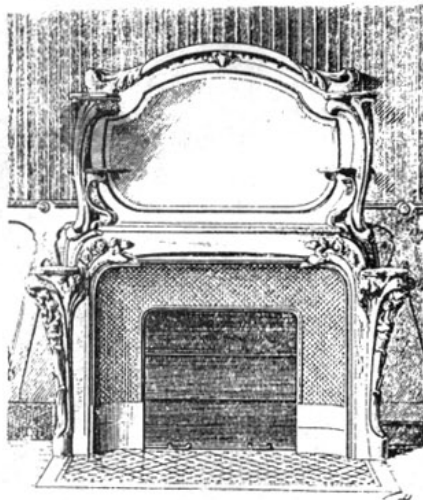

Парижъ. Домъ Schoellkoff (Av. d'Jena). Каминъ въ биллиардной.





A



B

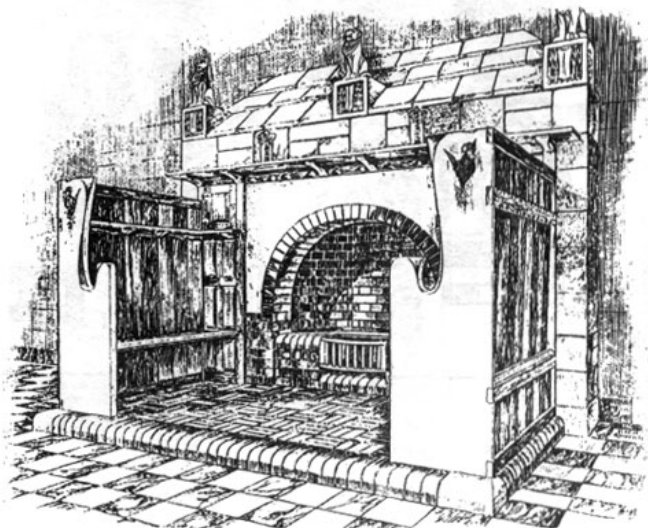

C

A. Парижъ. Castel Beranger.

Арх. Guilmard.

B. Портсмутъ (шт. Neu-Hampshire С. А. С. Ш.),  
Каминъ въ домъ г. Wentworth.

Арх. G. P. Fernald.

C. Проектъ камина.

Арх. John P. White.

D. Парижъ. Palais d'Orsay. Каминъ.

Арх. Laloux.

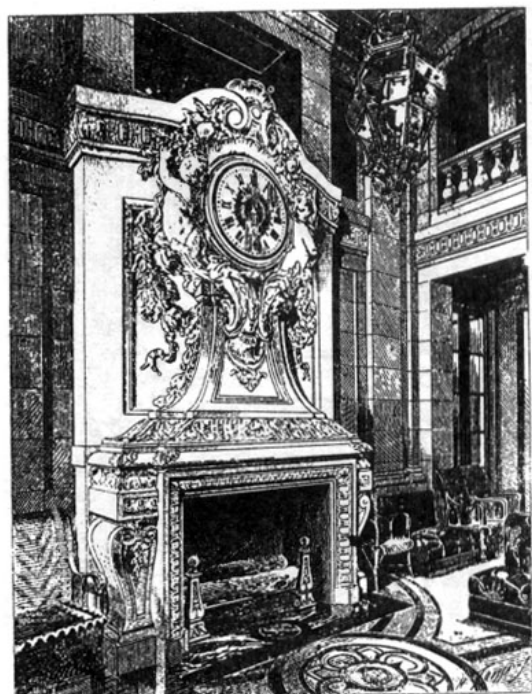

D

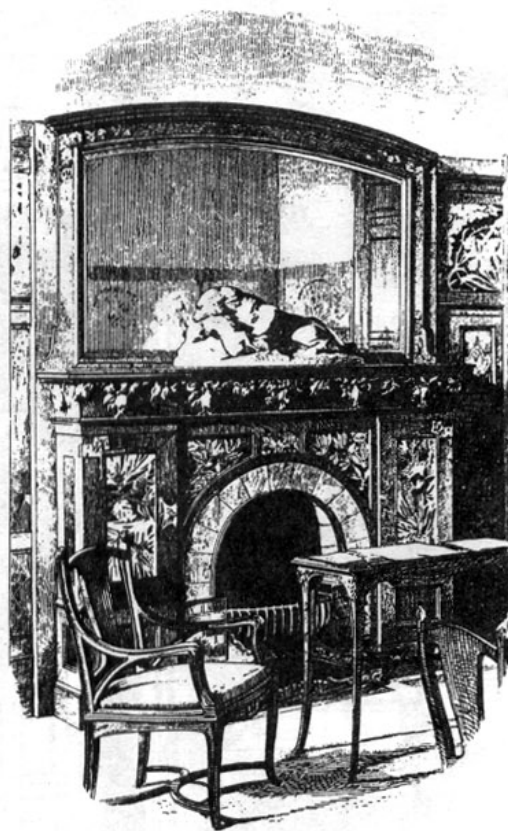

Каннъ. (Alpes Maritimes). Гостиница „Gallia“. Каминъ въ читальнъ.

Арх. Stoecklin съ синонь.

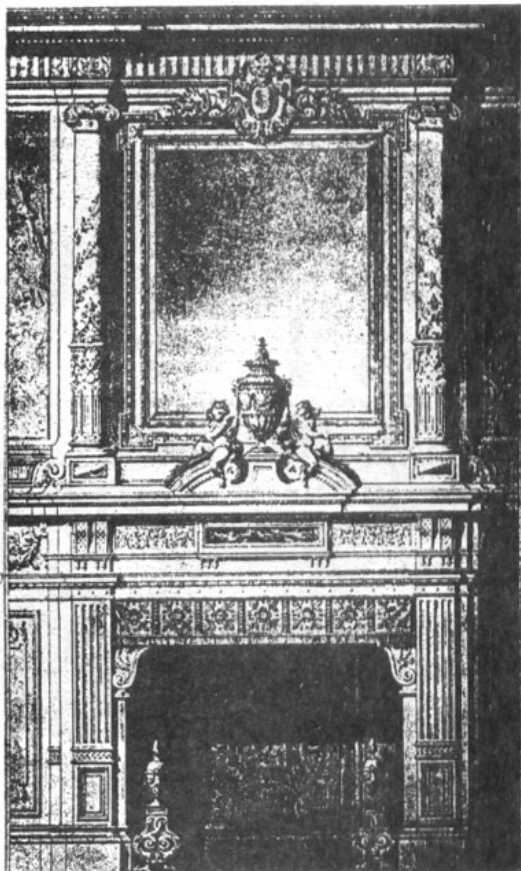

Каминъ для зала.  
Арх. Eug. Prignot.

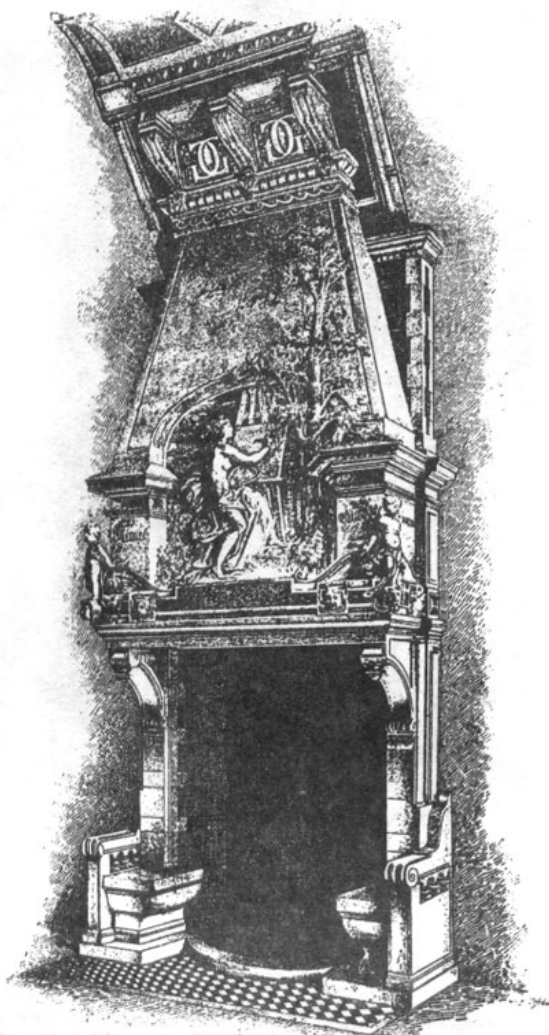

Nogent-s.-Marne. Каминъ въ усадьбѣ г. G.

Арх. J. Chéret.

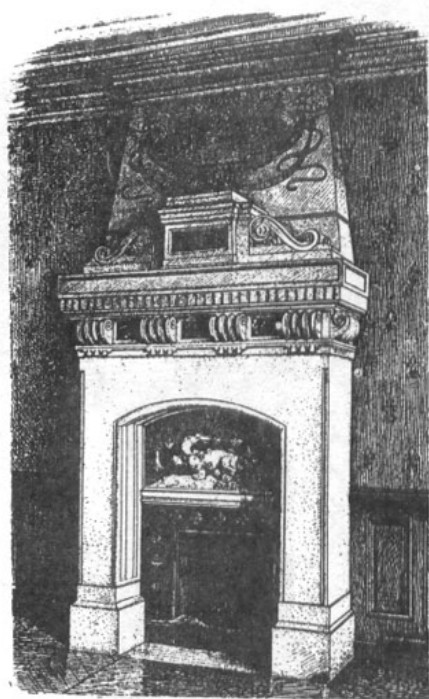

Fontainebleau. Каминъ въ залѣ Сберег. кассы.

Арх. Oct. Courtois-Suffit.

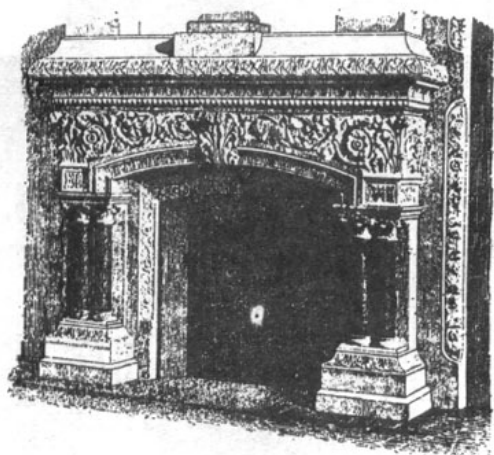

Каминъ.

Hotel de ville de Poitiers.

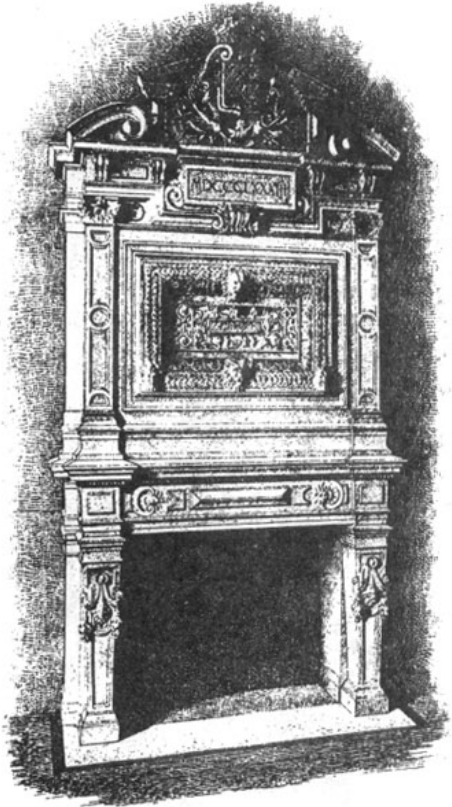

Hotel de ville de St Denis. (dep. Seine). Каминъ.

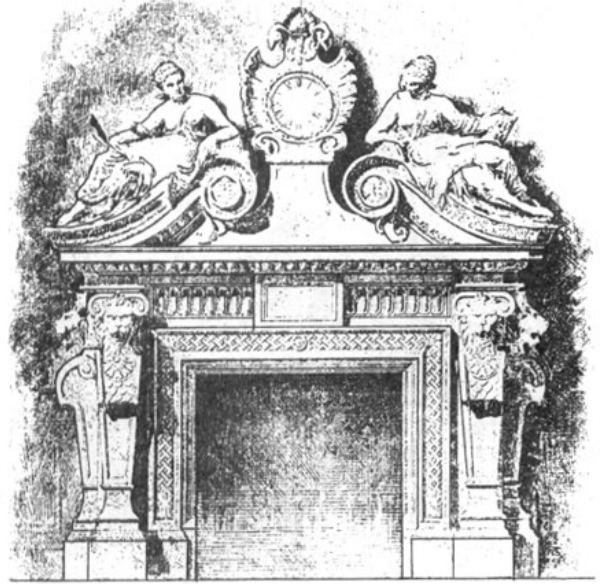

Проектъ камина для большого кабинета

Арх. А. Р. Clerc.

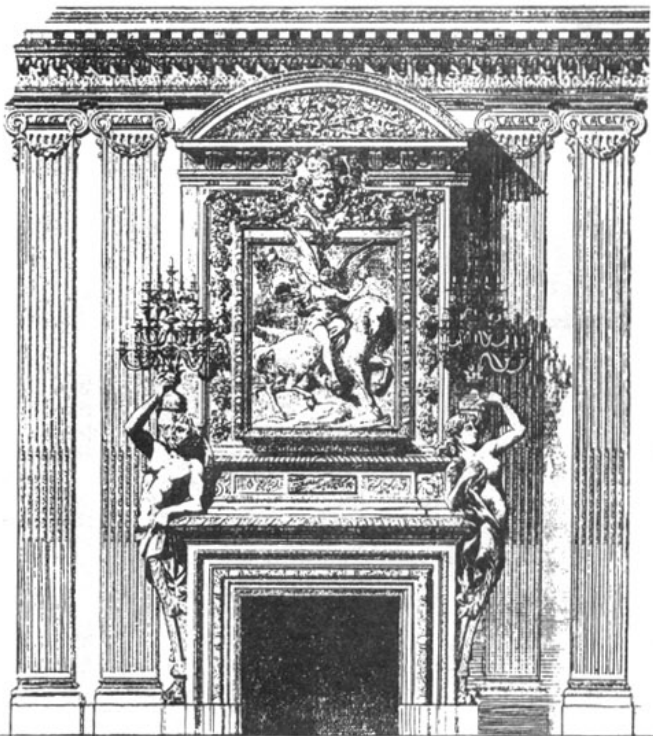

Каминъ рѣзной изъ орѣхового дерева съ позолотой.

Арх. Flachet et Cochet

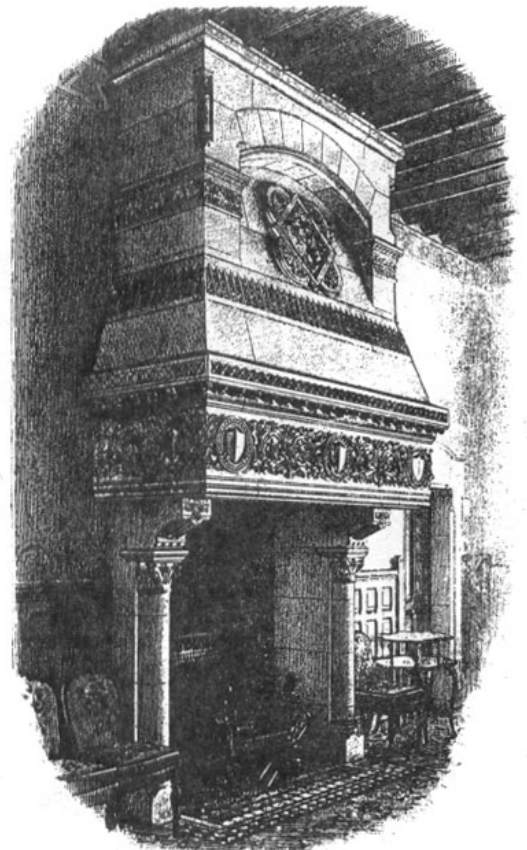

Парижъ. Особнякъ маркизы de Bethizy.

Арх. Lucien Magne.



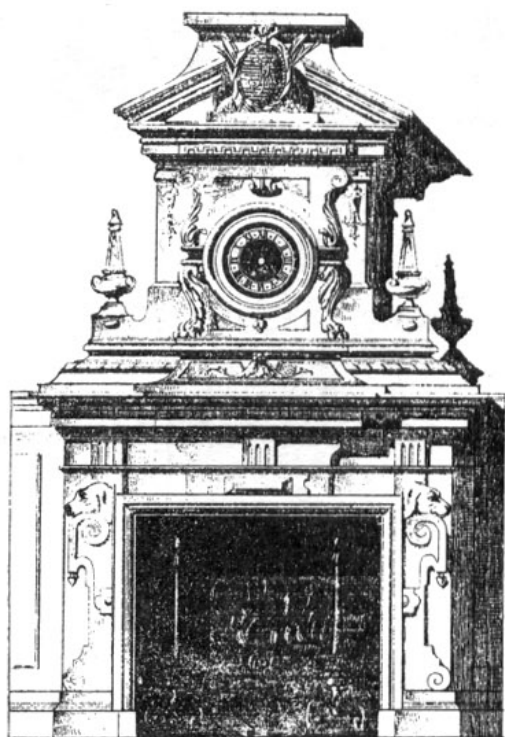

Каминъ.

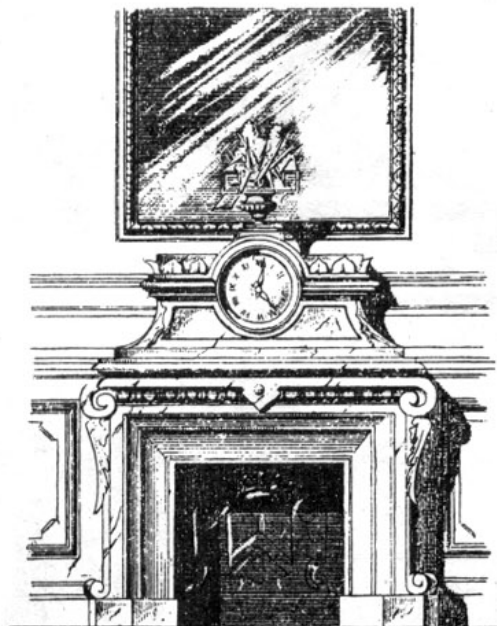

Каминъ.

Château de Baroux, près Airvault (Deux Sevres).

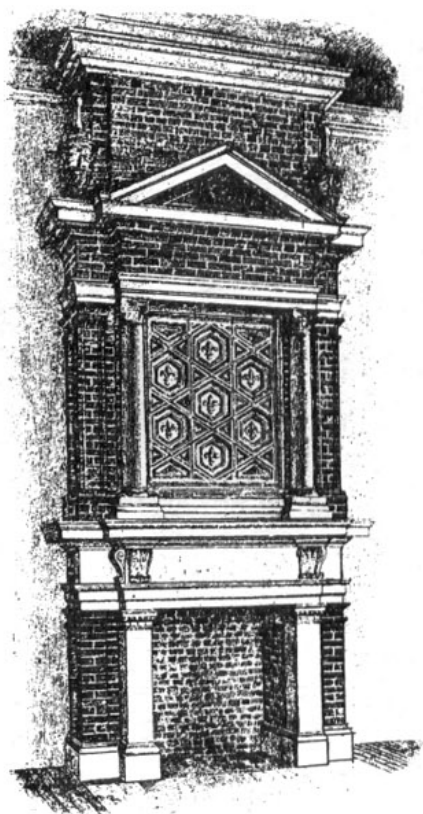

Каминъ въ стилъ François I въ замкъ S-te Germain en Laye.

Арх. Millet.

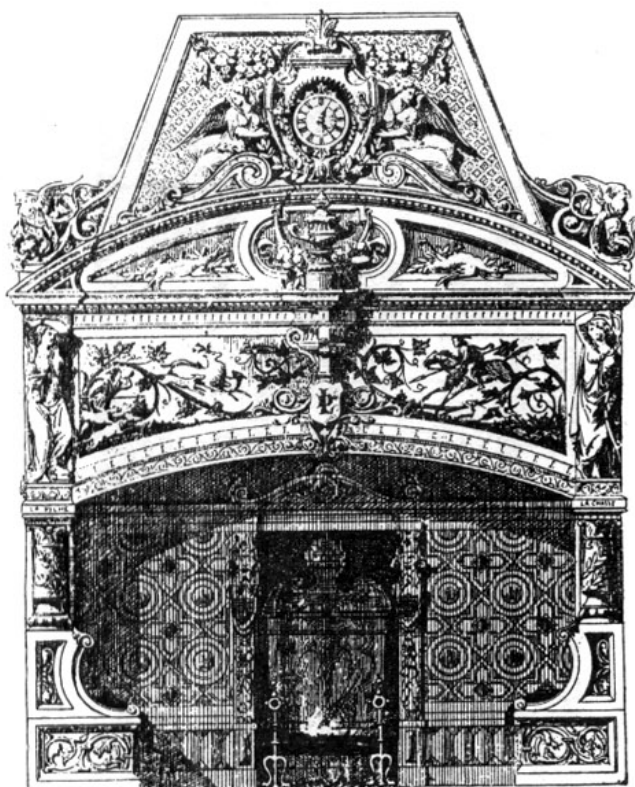

Проектъ большого камина съ нишей.

Арх. Virbent.



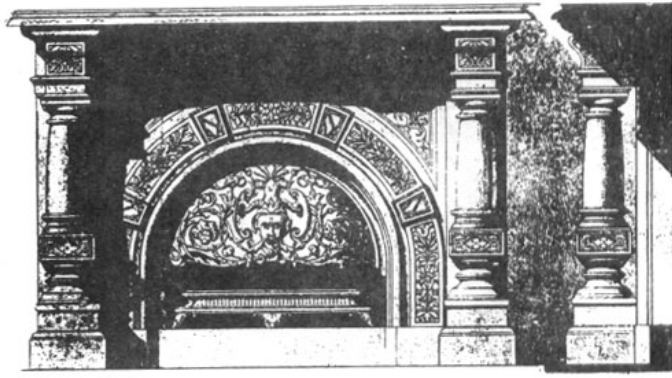

Лейпцигъ. Вилла Meissner. Каминъ.

Арх. Ende & Böckmann.

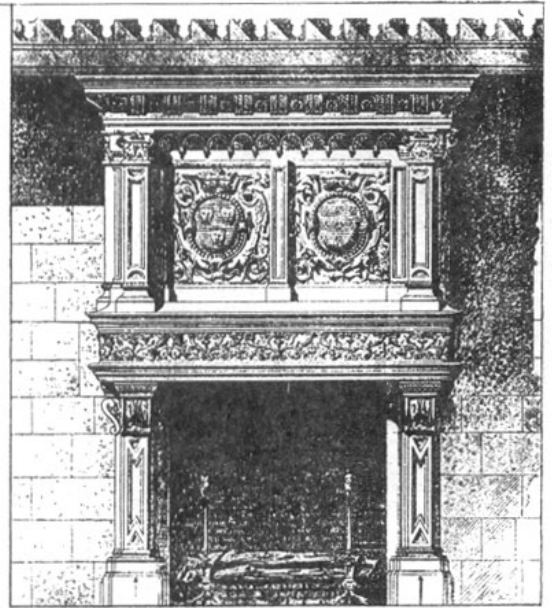

Каминъ большого зала въ замкѣ Villegongis (деп. Indre).

Арх. Aubry.

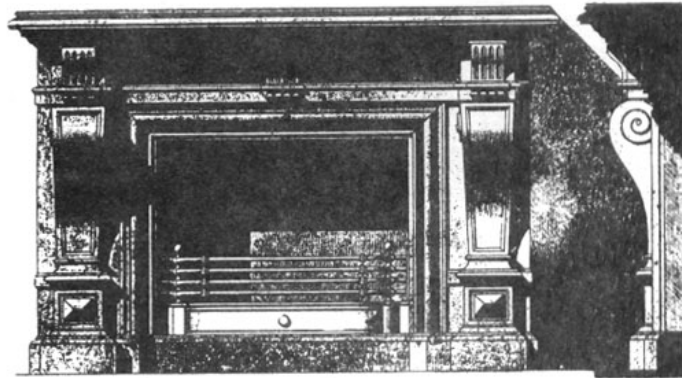

Лейпцигъ. Вилла Meissner. Каминъ.

Арх. Ende & Böckmann.

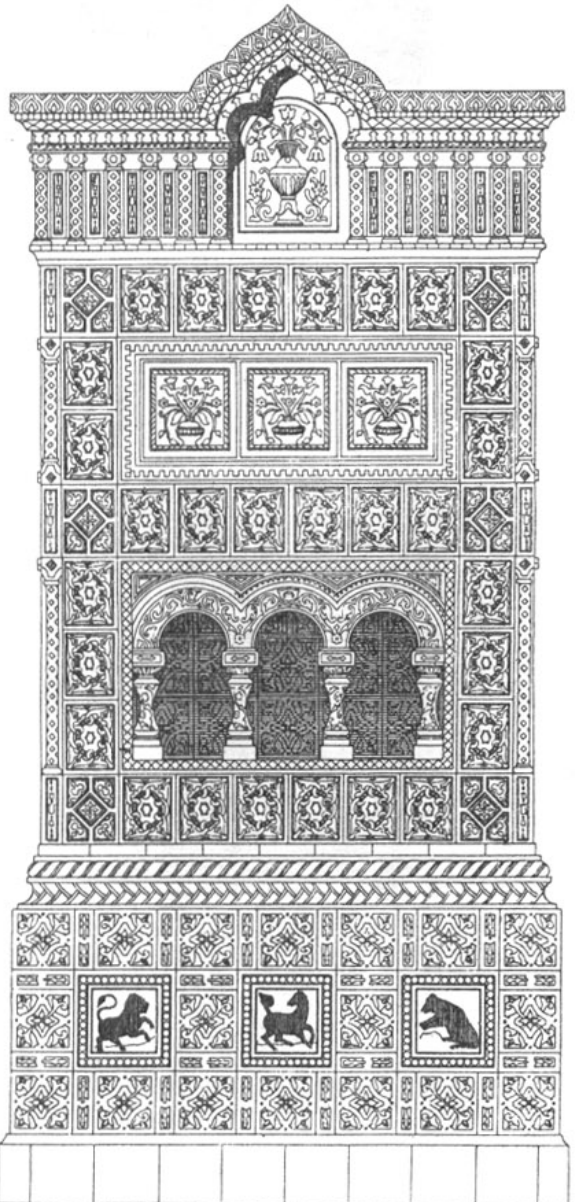

Проектъ изразцовой печи.

Арх. Даль.

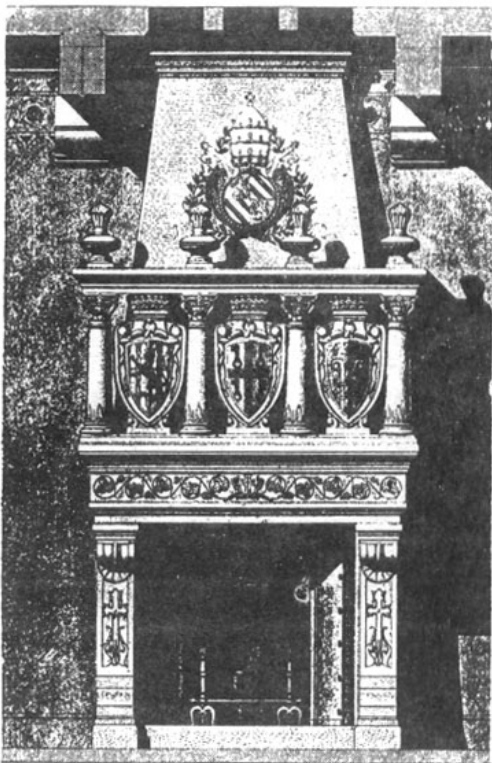

Вауваис (деп. Oise). Каминъ во дворцѣ Епископа.

Арх. Vaudremer.

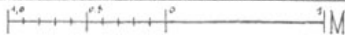

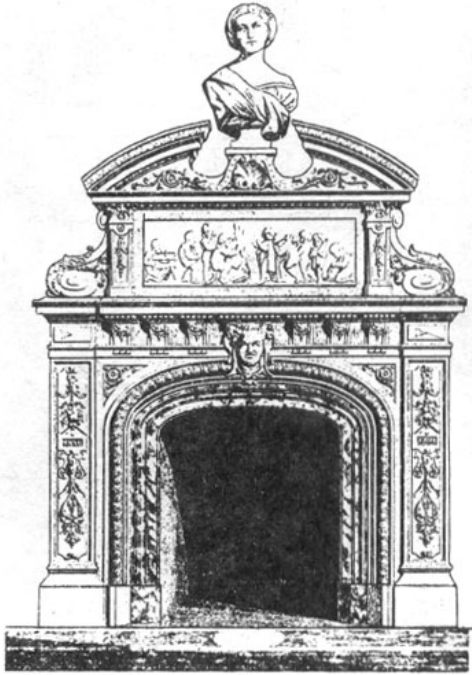

Парижъ. (Rue de Berlin).  
Арх. L. Dupré. Скульп. А. Millet.

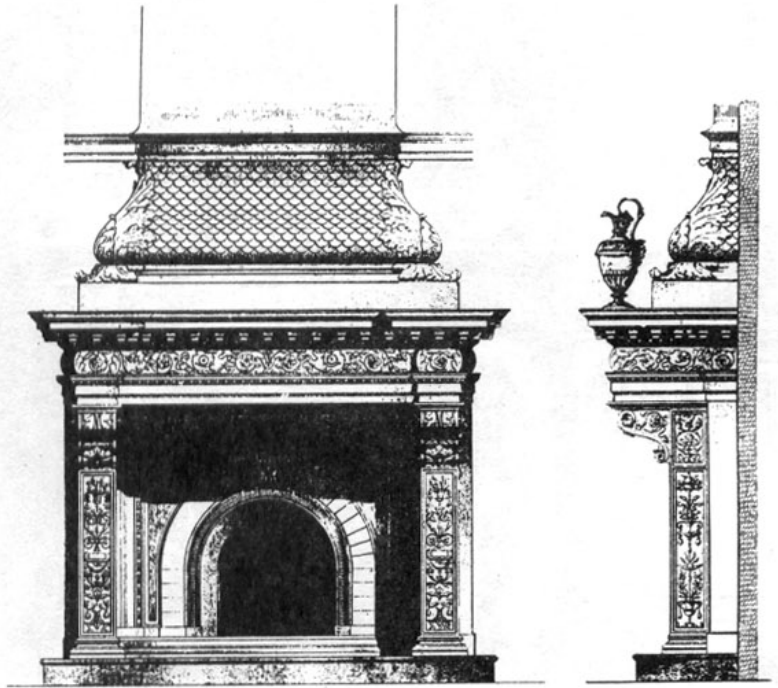

Берлинъ. Павильонъ въ саду г. Neckmann.  
Арх. Hugo Licht. Ион. Stiller.



Гренобль. Домъ префектуры.  
Арх. Questel.

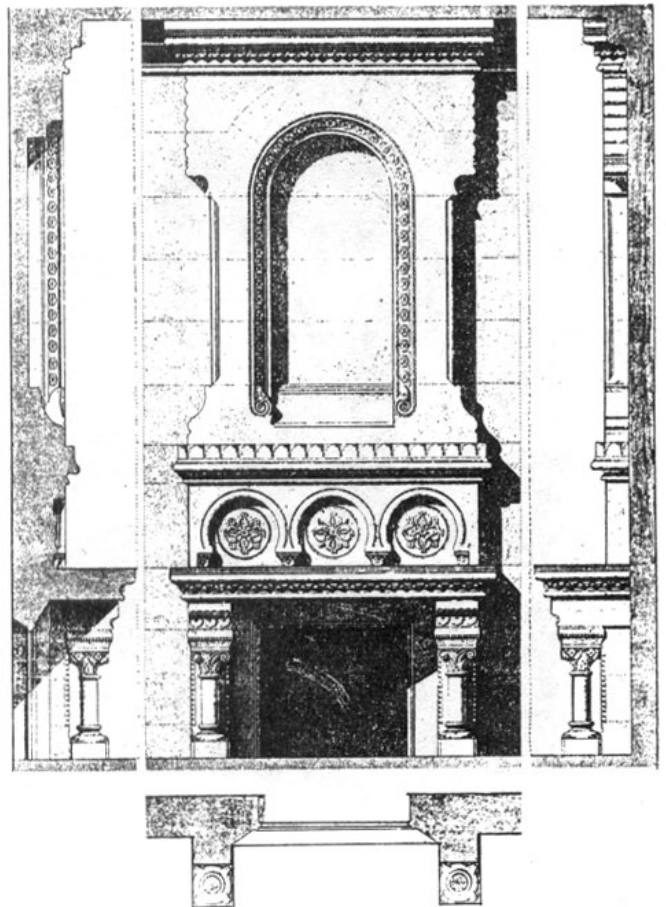

Бордо. Монастырь.  
Арх. Aymar Verdier

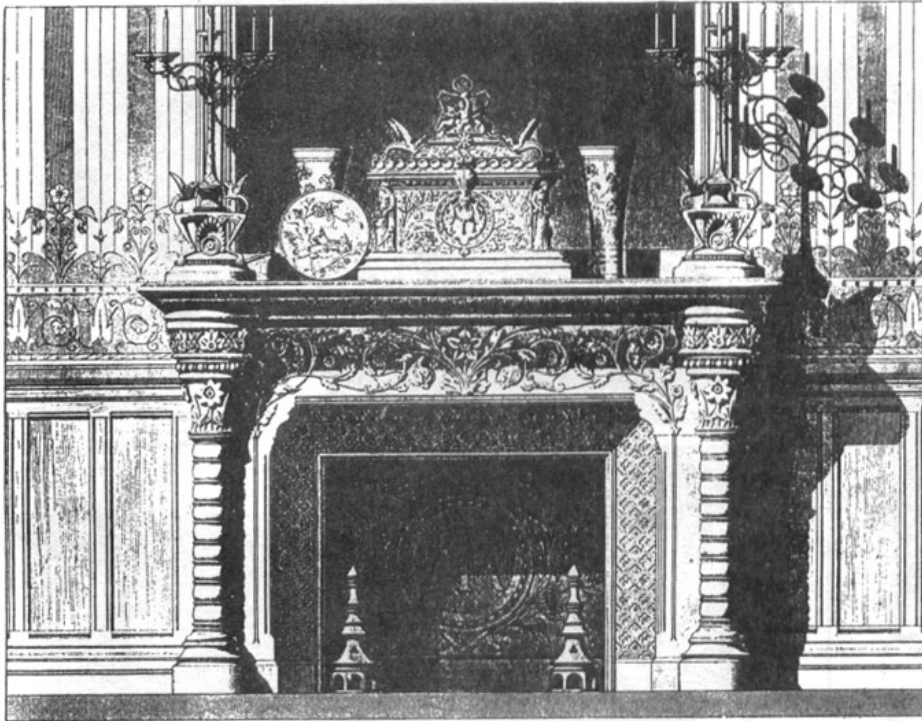

Каминъ для зала частного дома.

Арх. Ruprich-Robert



Ратуша въ Château-Thierry. Каминъ.

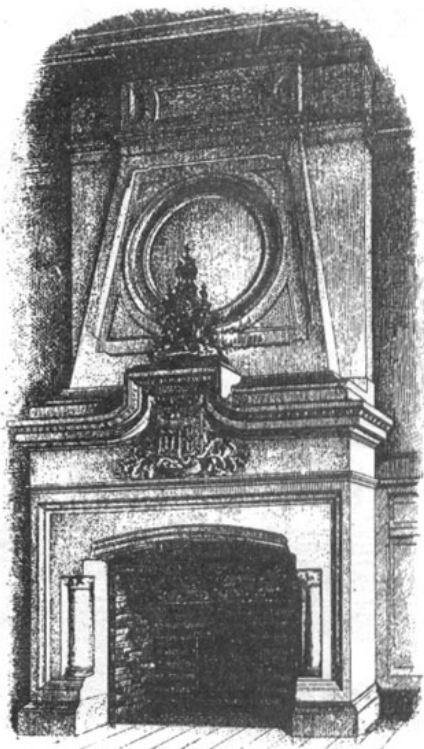

Каминъ въ здании мэрии общины du Perreux (dep. Seine).

Арх. P. Mathieu.

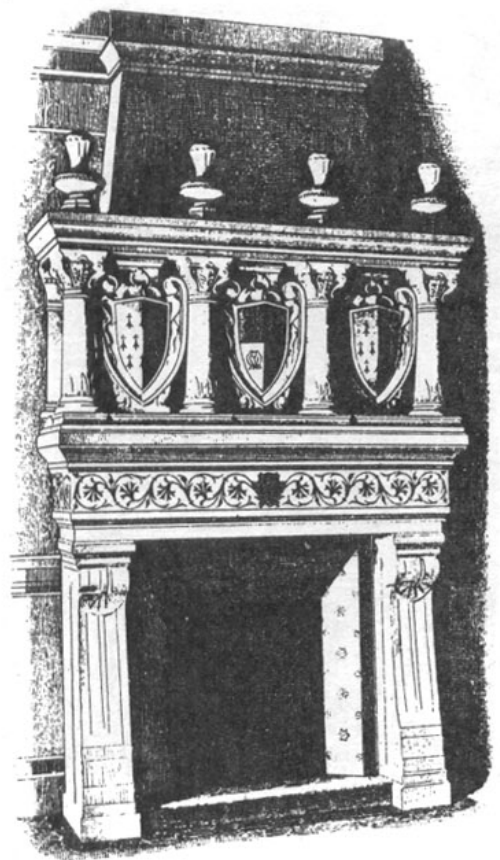

Проектъ каминъ.

Арх. Vaudremer.



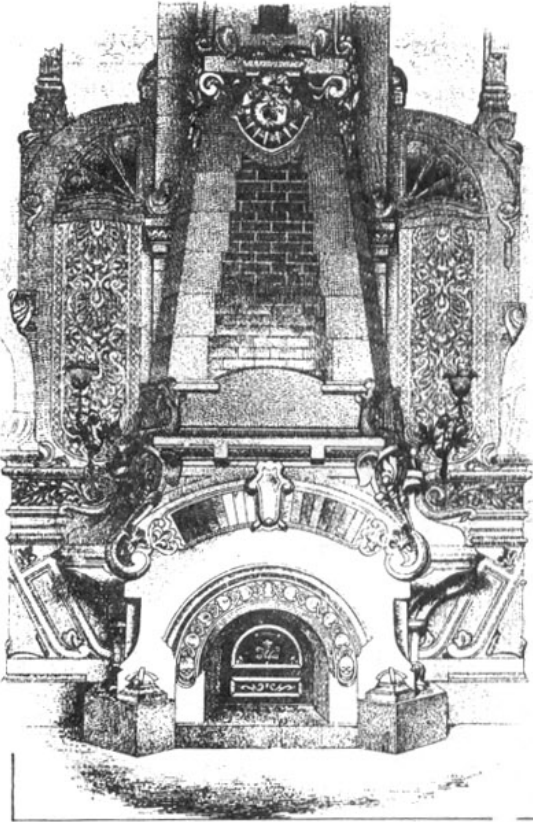

Марсель. Ресторанъ de la Lune (rue Noailles).

Арх. E. Bertz.

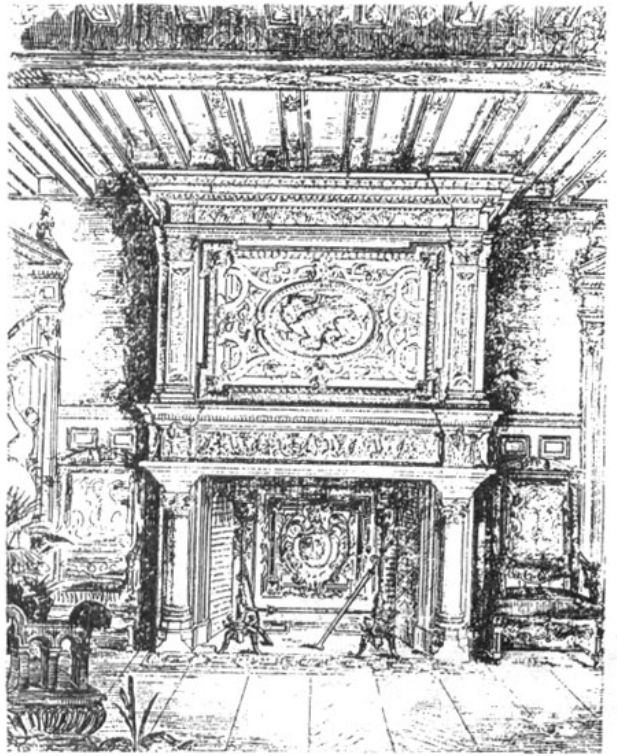

Chelles (деп. Seine et Marne, близъ Париза). Вилла Gasnier-Guy. Каминъ.

Арх. Frantz Jourdain.

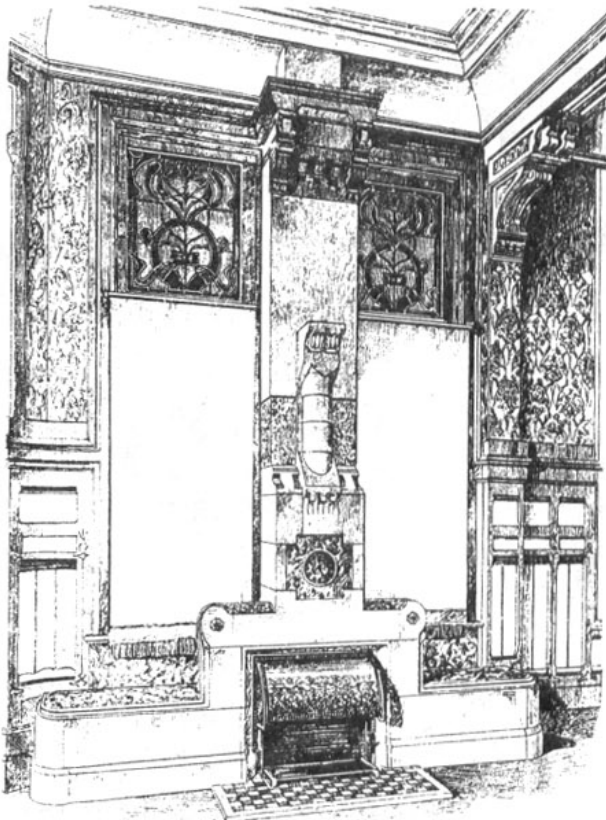

Роттердамъ (Голландія). Торговый домъ Н. Вваакман & С<sup>н</sup>. Каминъ въ залъ собраній.

Арх. В. Hoogkass.



Вилла Fontenay-aux-Roses.

Арх. L. C. Boileau.



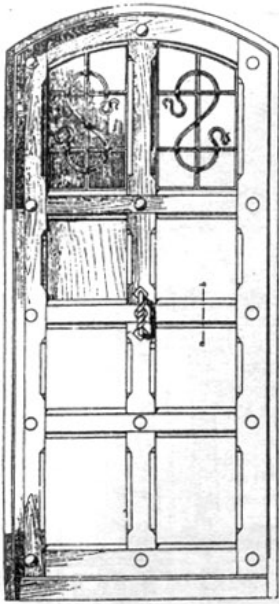

Мотивы  
столярныхъ дверей  
по Краuth'у.

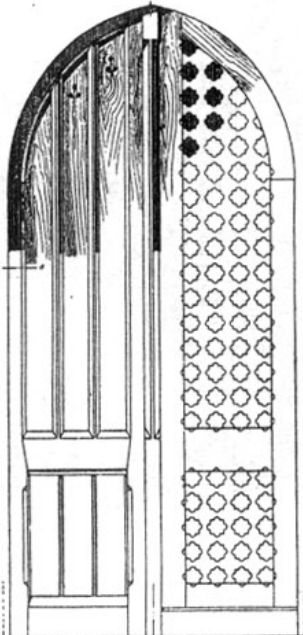
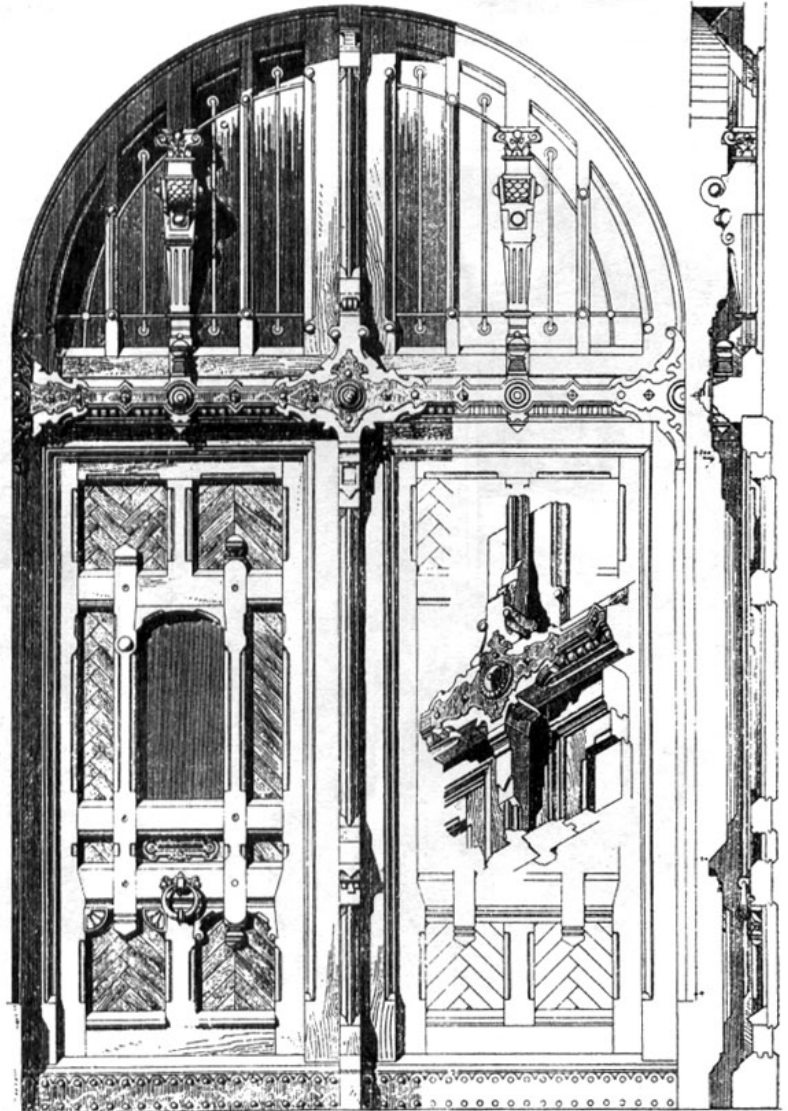
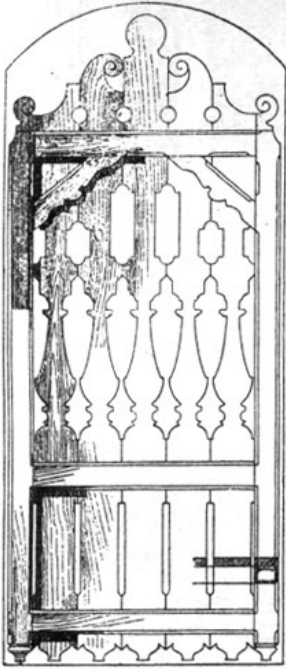
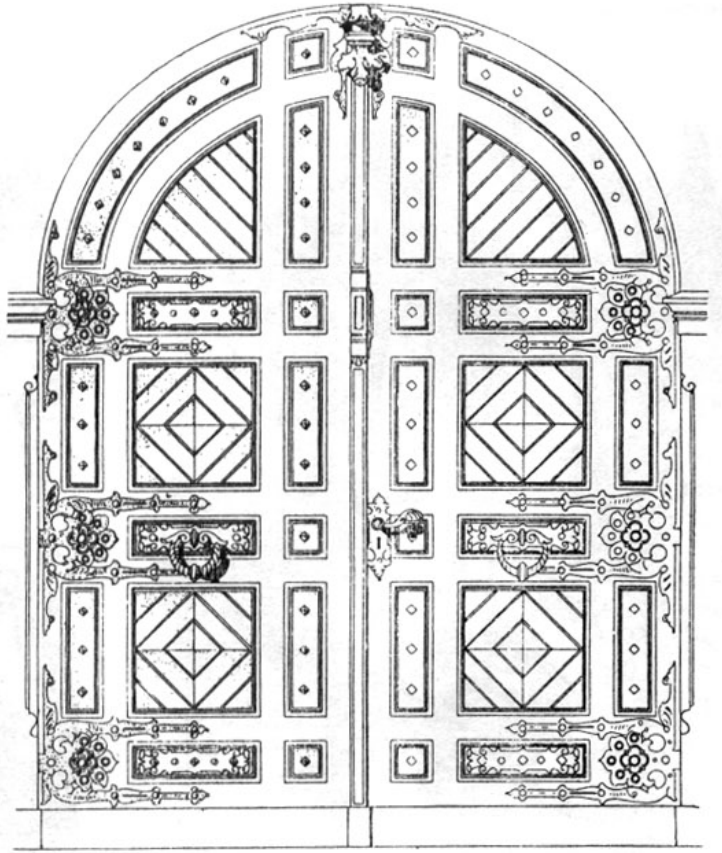

Парадная дверь въ частномъ домѣ.  
Вѣна.

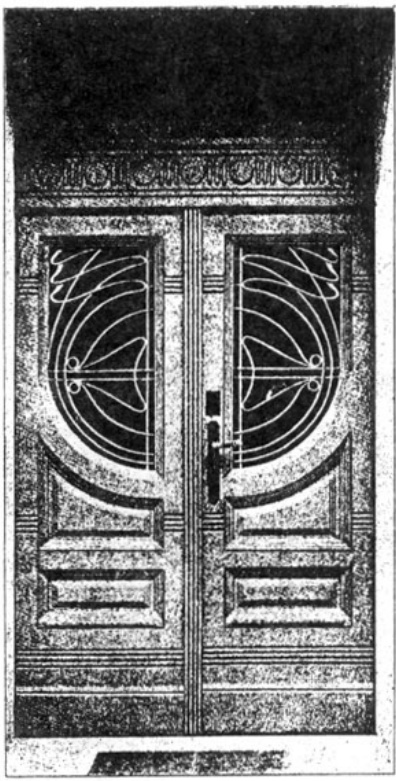

Арх. Ad. Ritter von Inffeld.

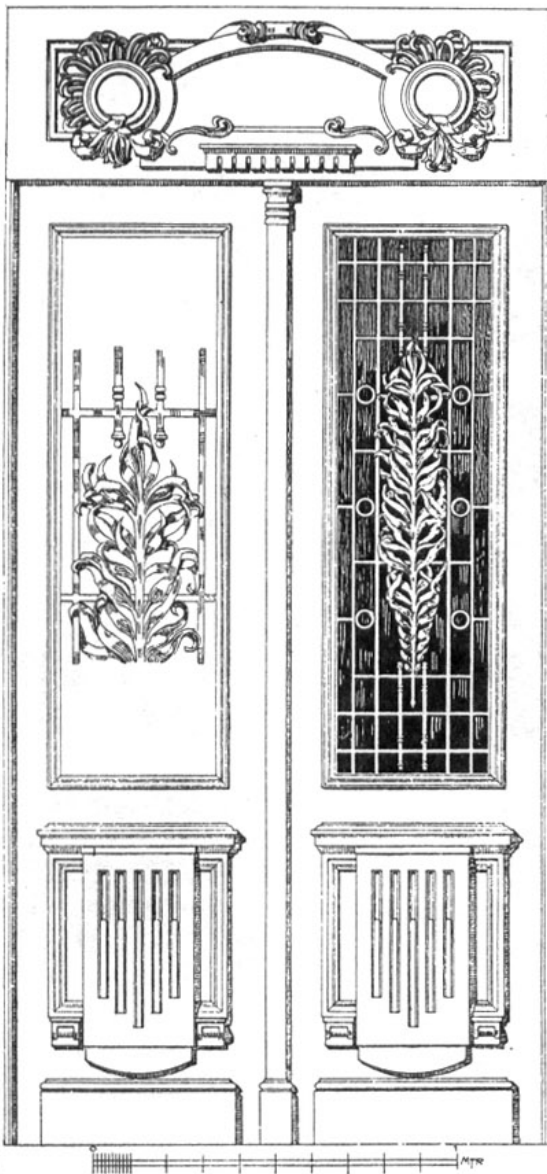

Wien (Frankenberggasse. 12).  
Арх. Wilhelm Jelinek.

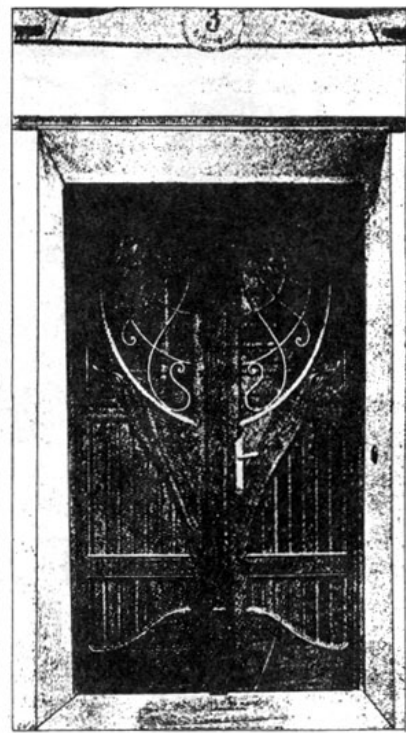

Арх. Hans Dworak.

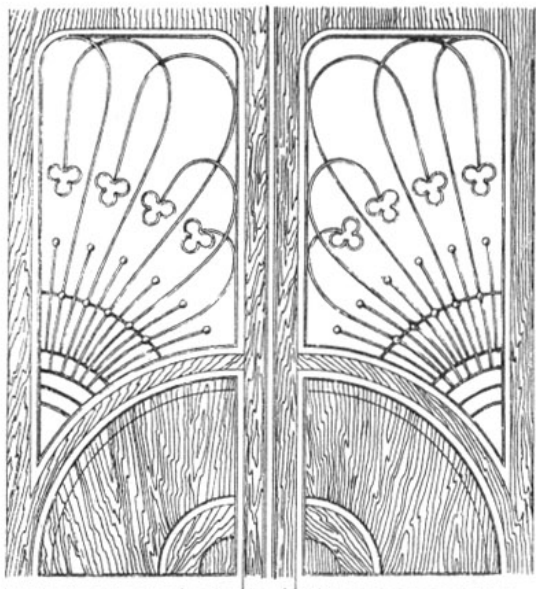

Часть деревянной двери.

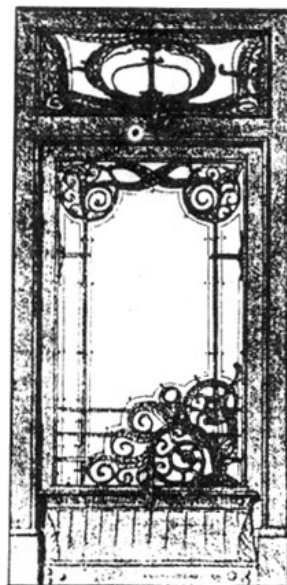

Налѣзная дверь въ деревянной рамѣ.

Арх. А. König (Берлинъ).

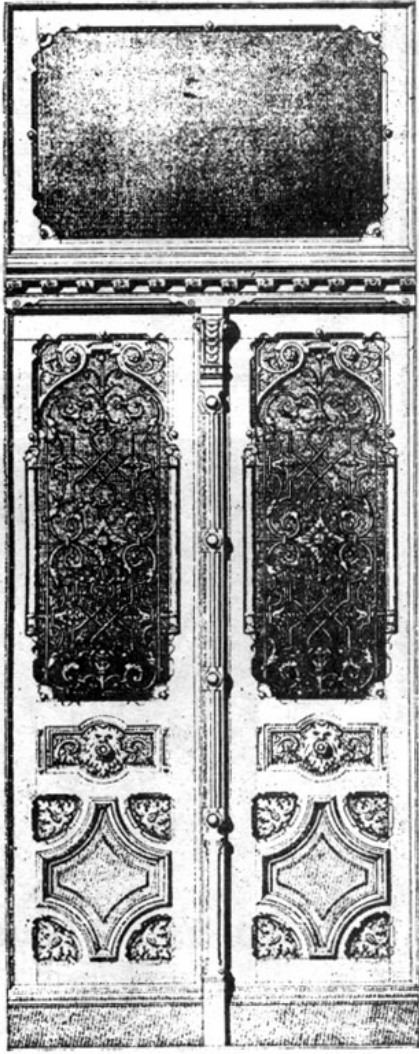

Арх. Ritter & Riegel (Берлинъ).

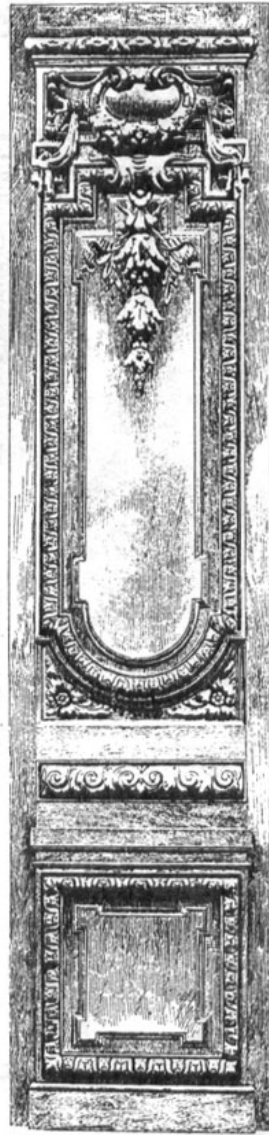

Арх. Н. Рарелт (Парижъ).

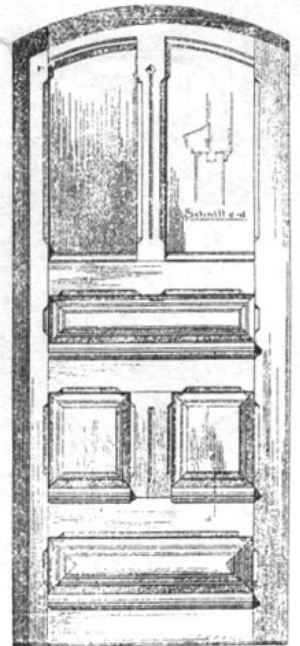
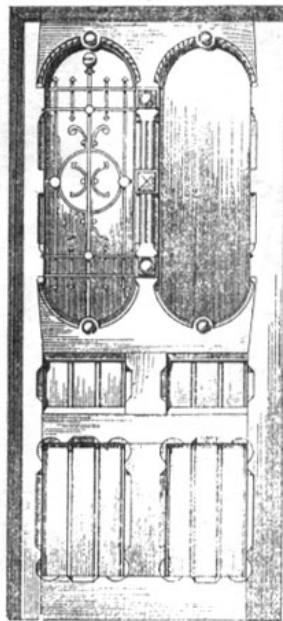
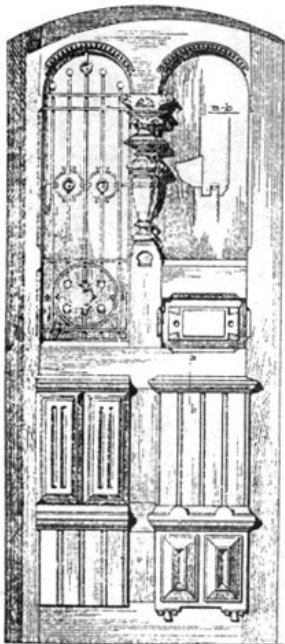
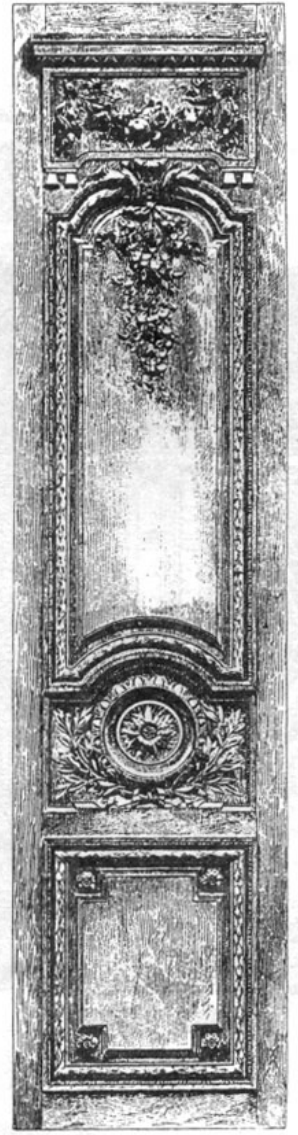

Отпярныя дври по Krauth'y.



# ДВЕРИ

Мотивы дверей въ новомъ стилѣ.

По Em. Fellingery.

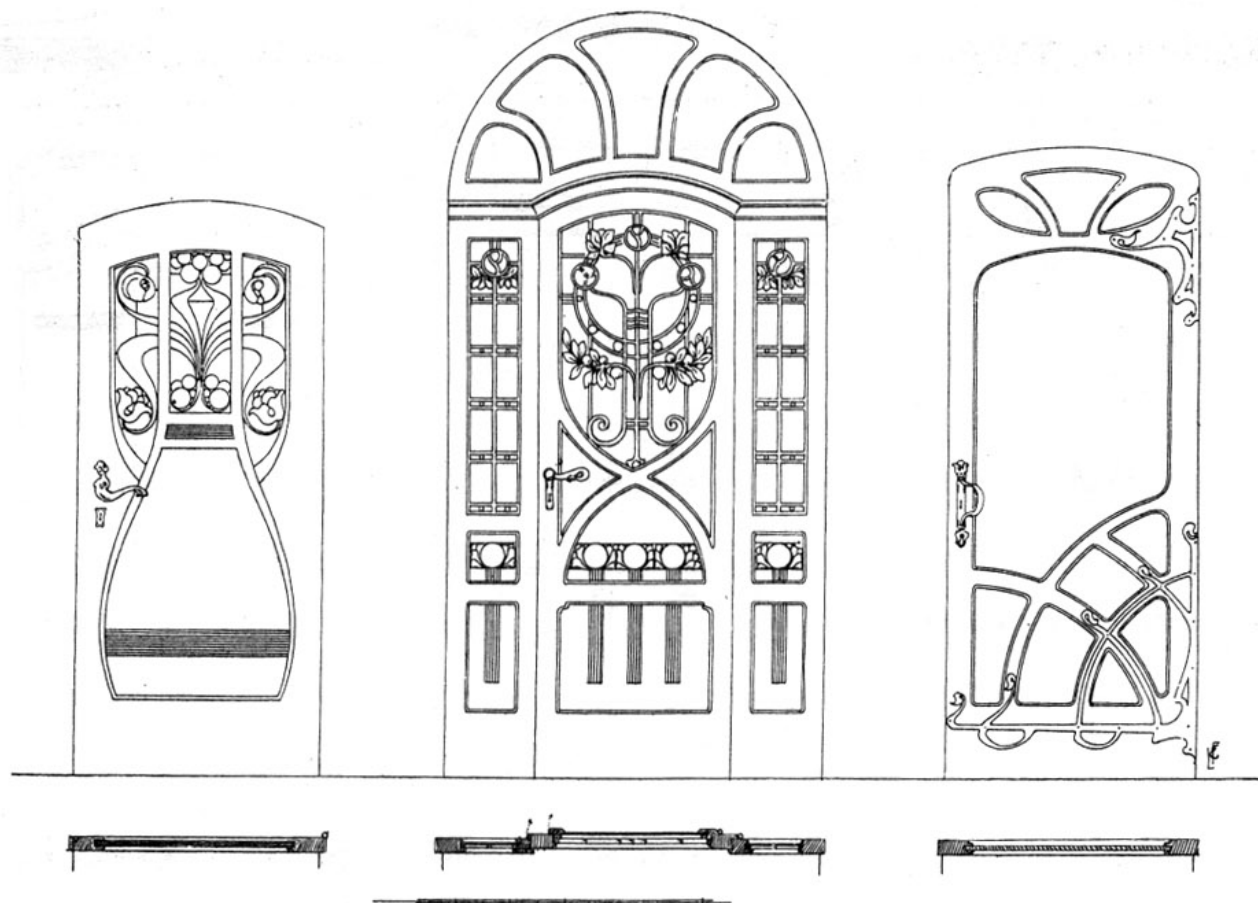
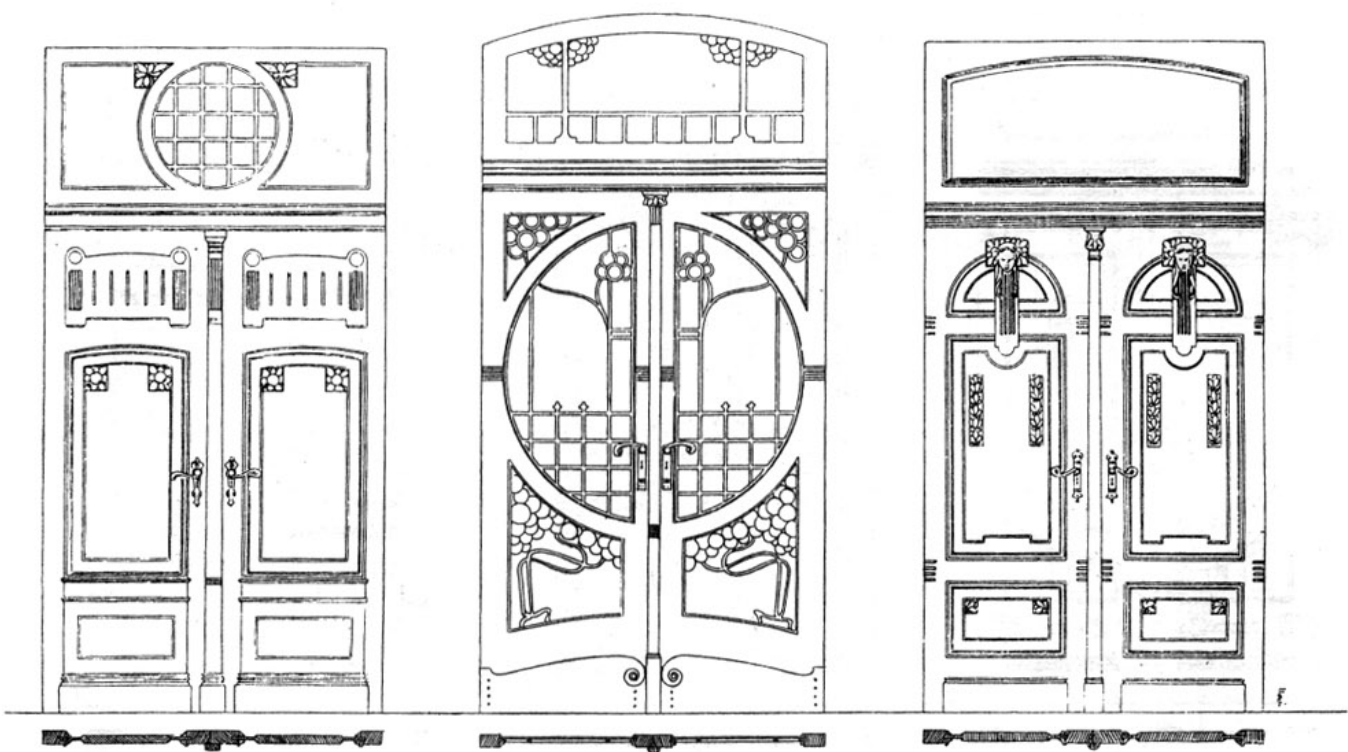



# ДВЕРИ

Мотивы дверей въ новомъ стилѣ.

По Еп. Fellinger'y.

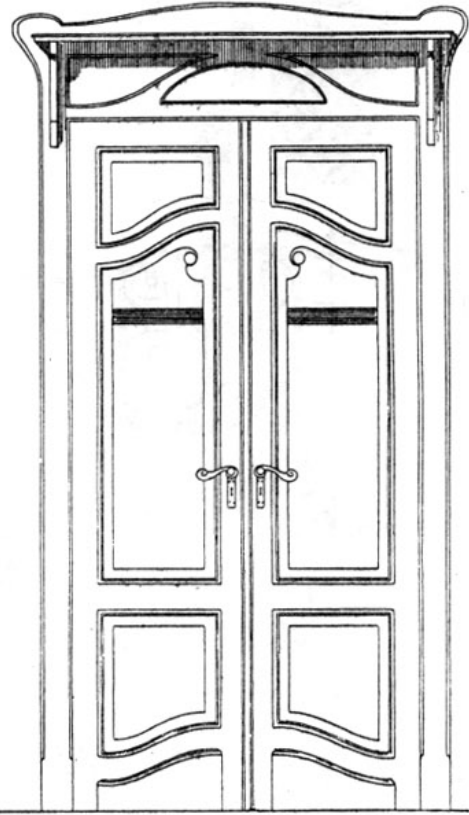
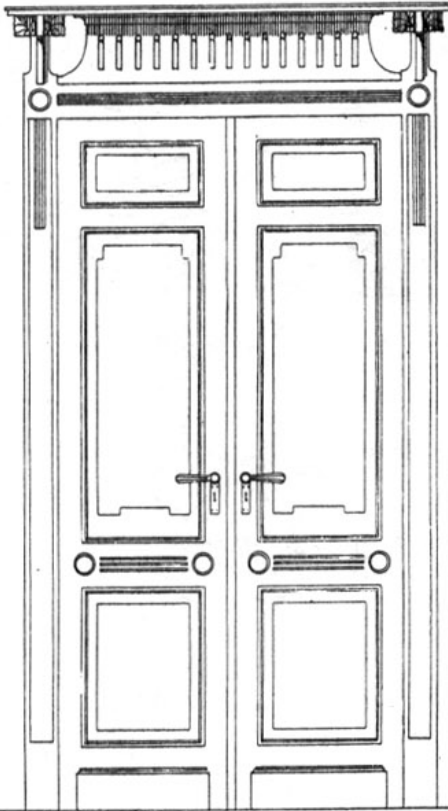
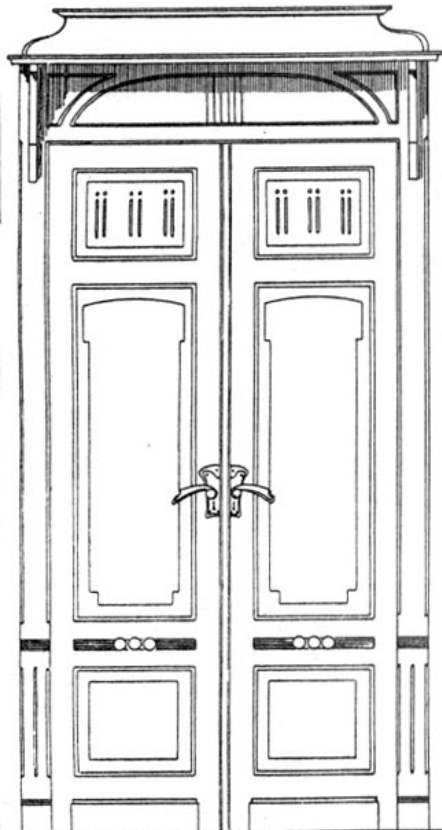
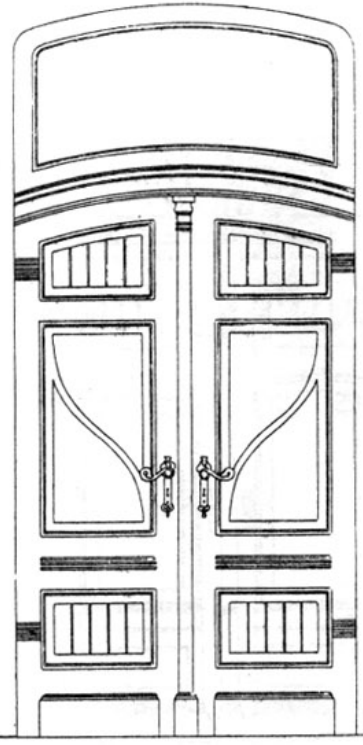
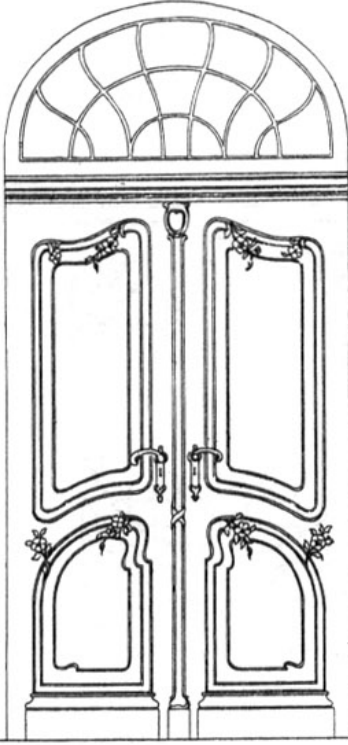
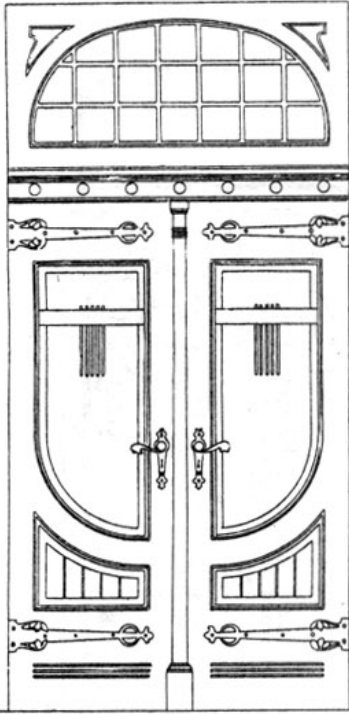

Мотивы дверей въ новомъ стилѣ по Emericch Fellinger'y.

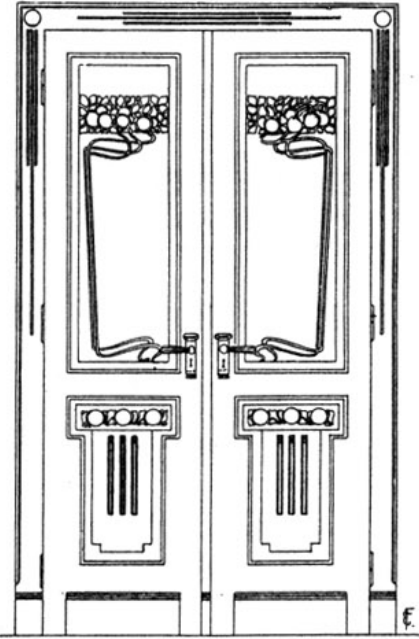
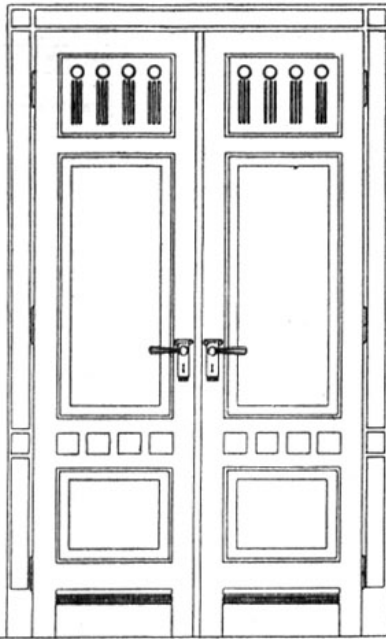
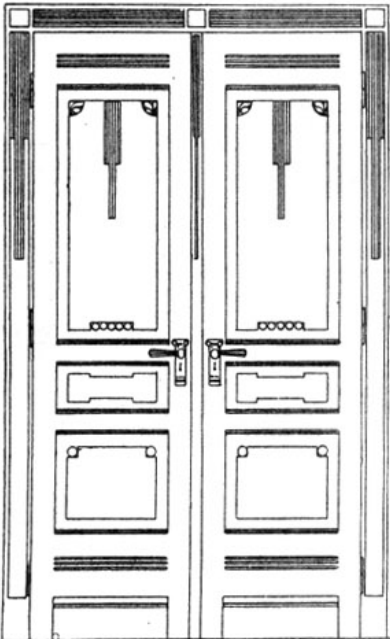
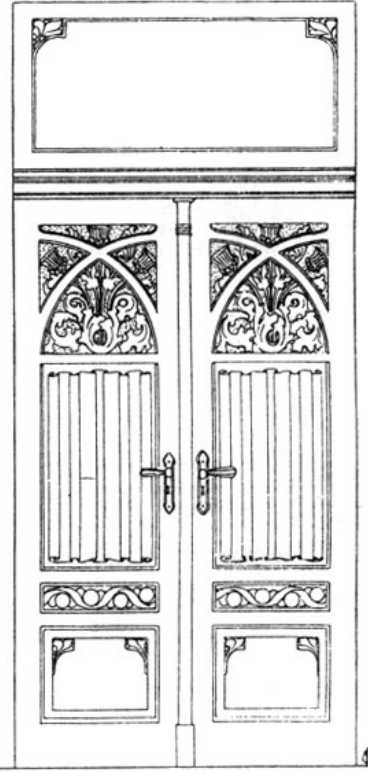
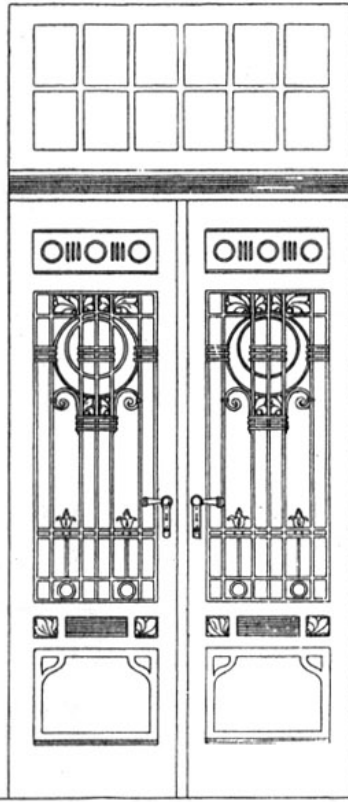
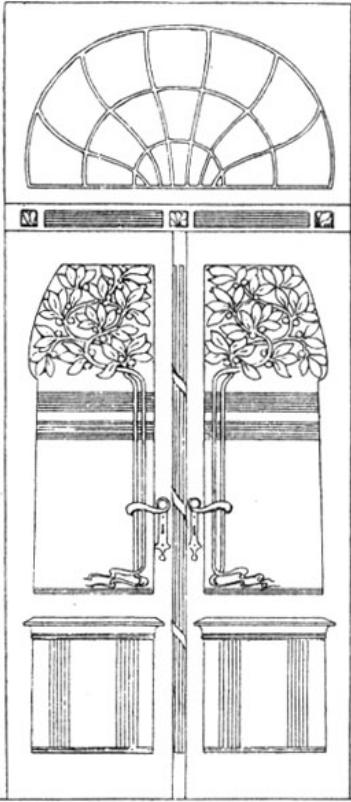

Мотивы дверей въ новомъ стилѣ по Emericch Fellinger'у.

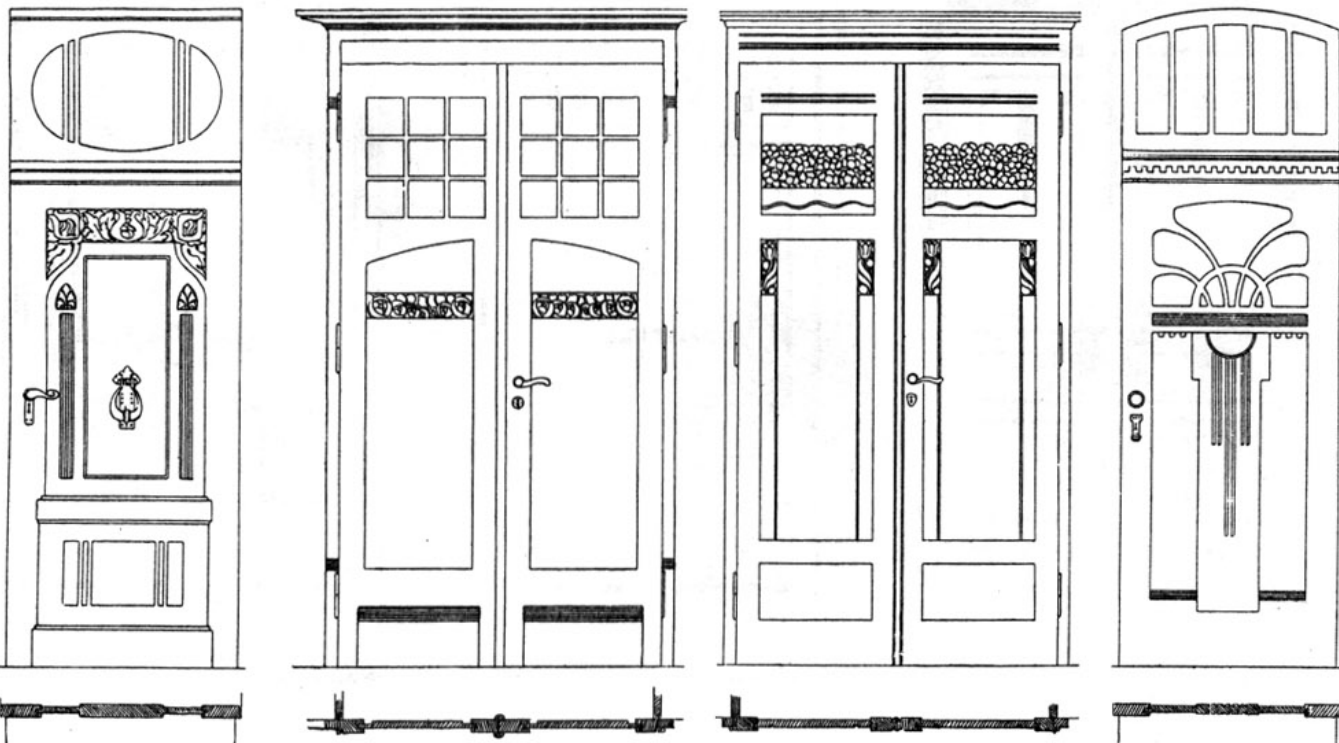
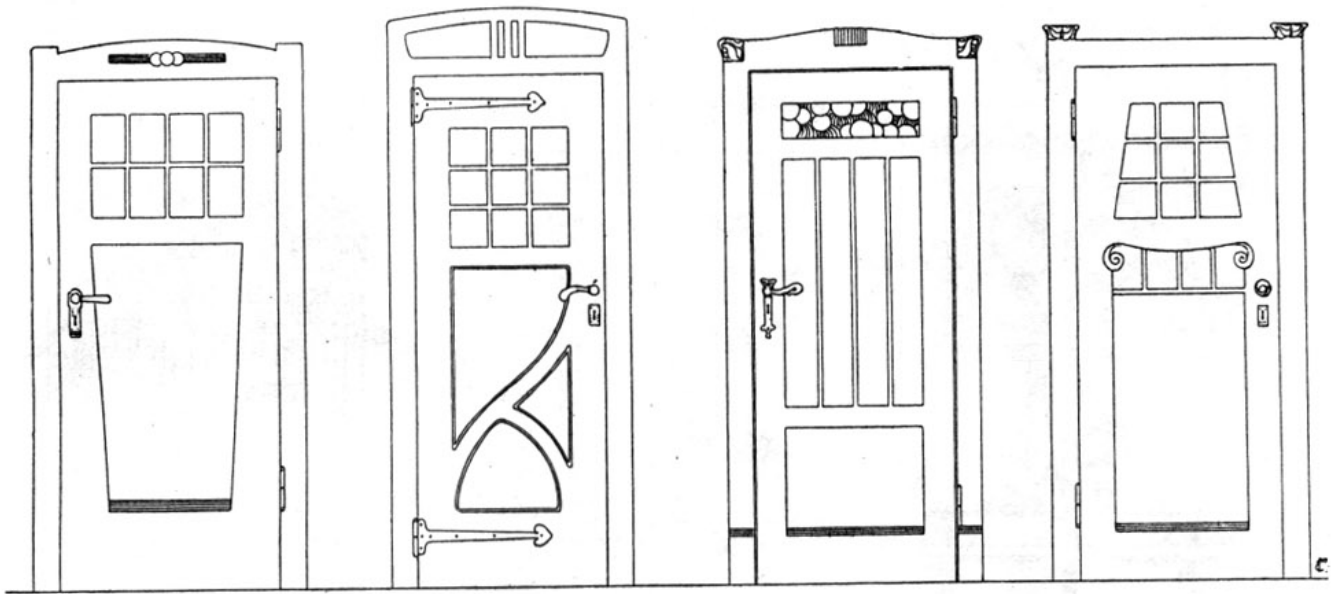

Одно—двустворные двери по Krauth'у.

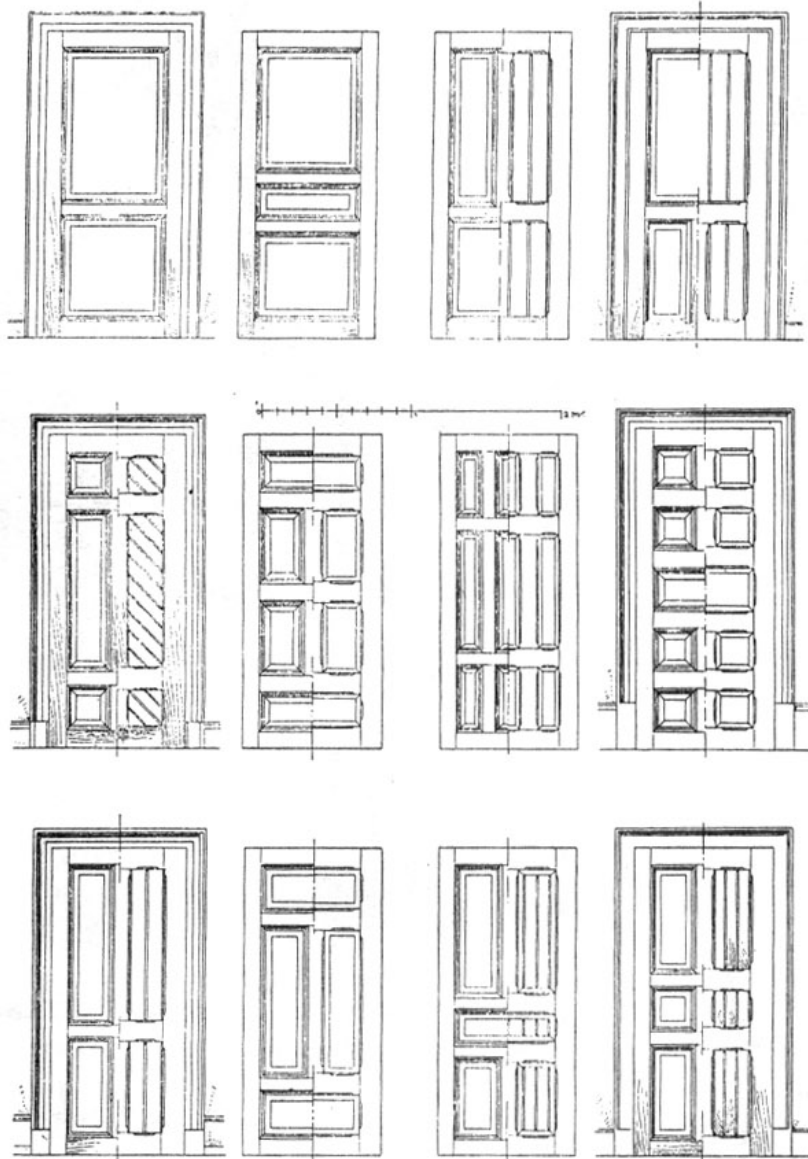

Домъ г. Штрауса въ С.-Петербургѣ.

Парадная дверь.

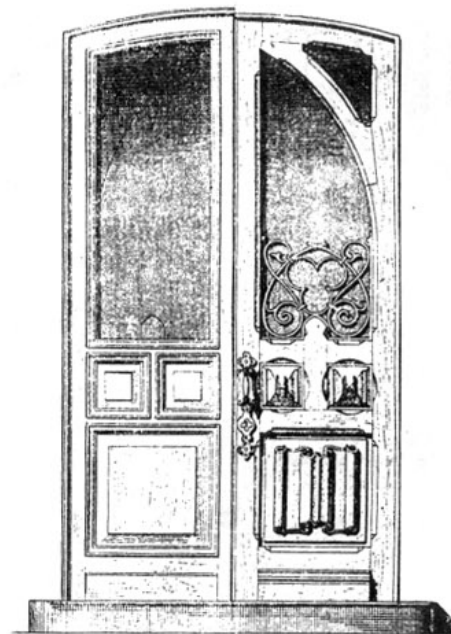

Задняя сторона.

Лицевая сторона.

Арх. В. А. Шретеръ, I. О. Нитнеръ.

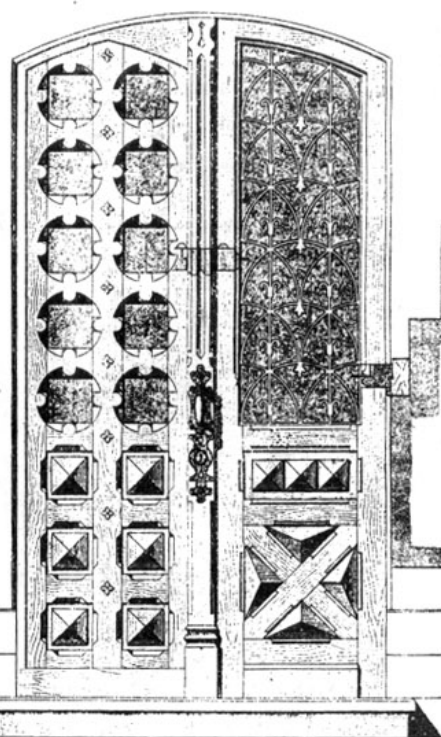

Домъ г. Ниссена въ О.-Петербургѣ

Арх. В. А. Шретеръ.

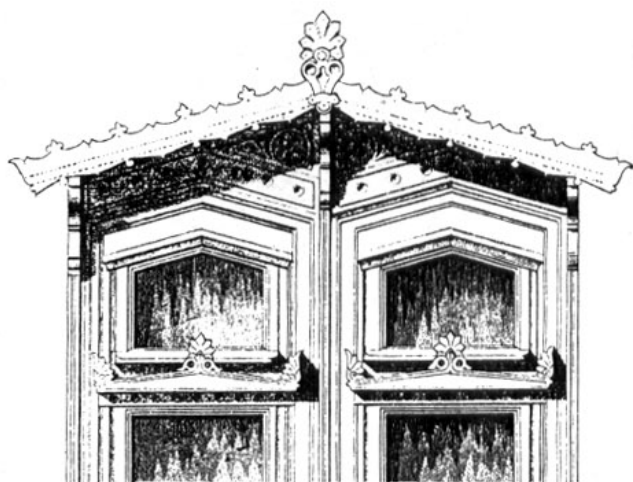

Арх. В. Liebold.



Мотивы столбчатых дверей по Краuth'y.

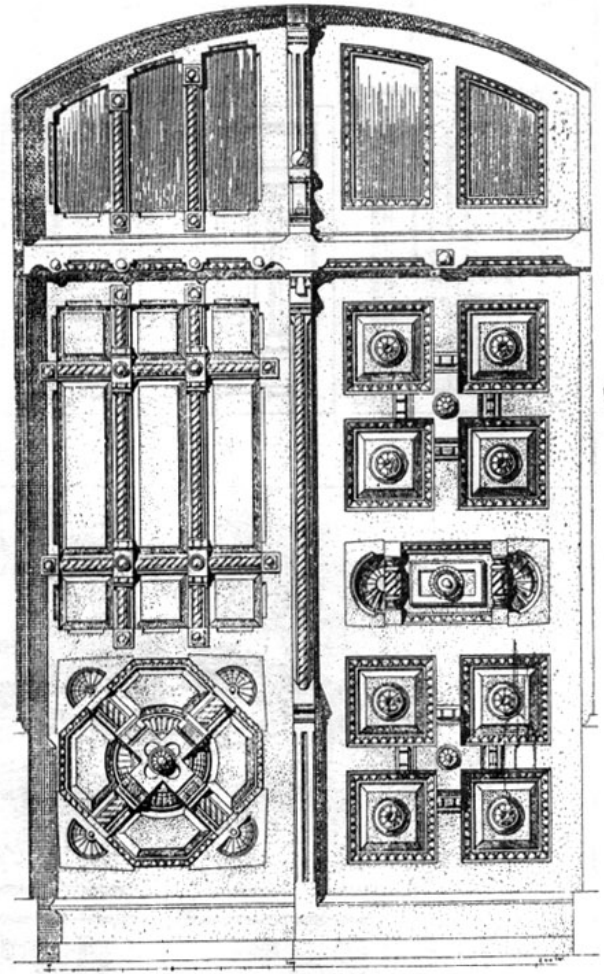
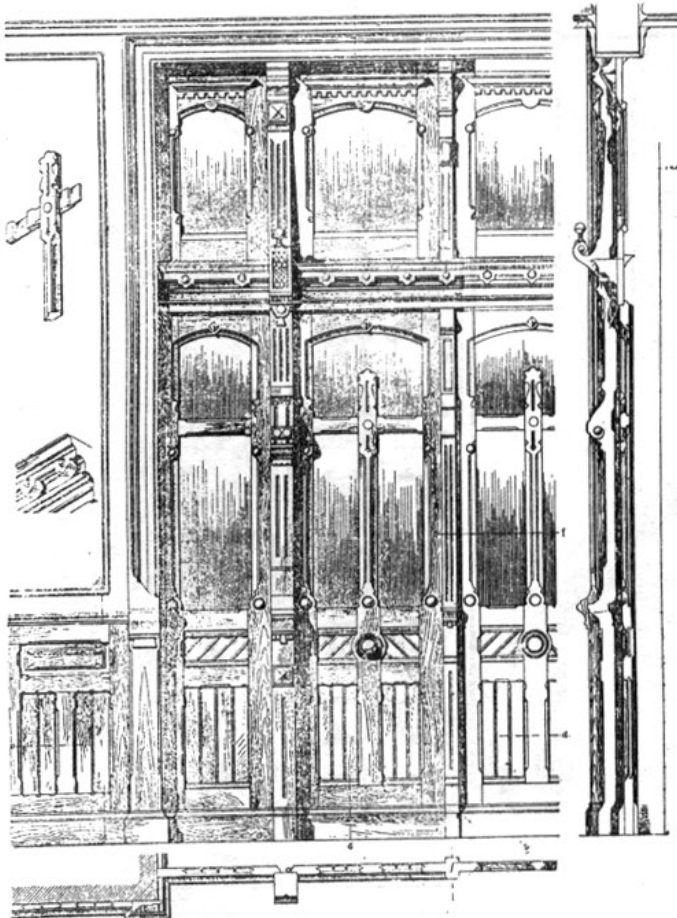
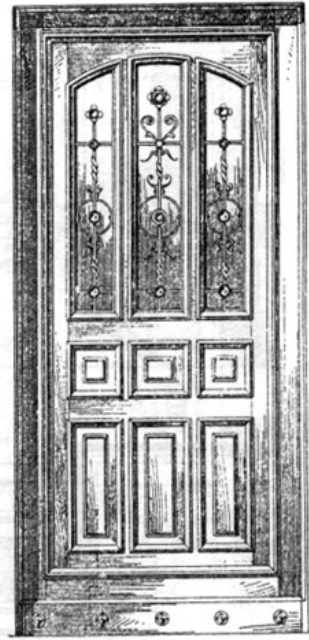
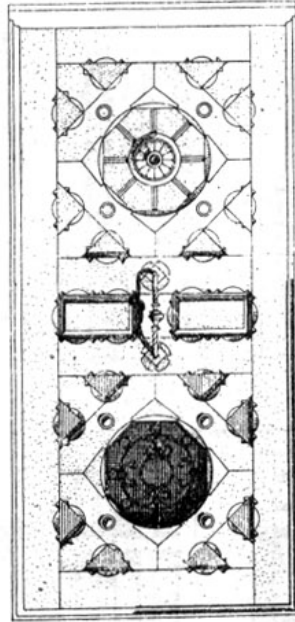
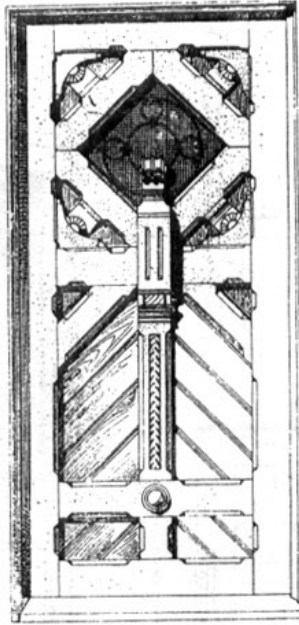
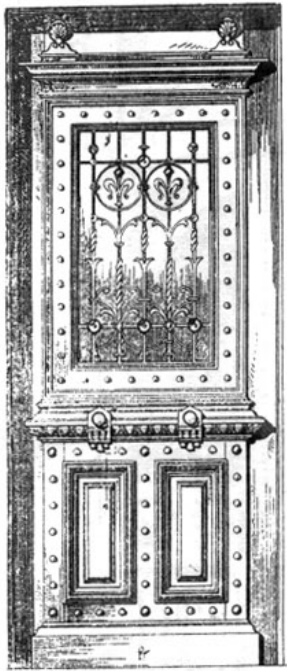

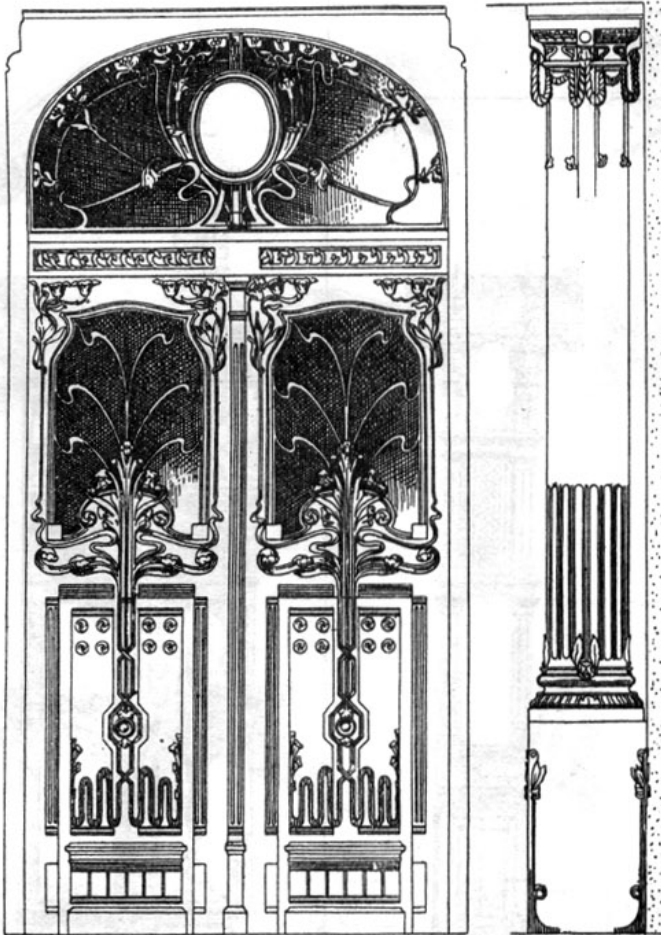

Нельская дверь.

Мотивы дверей въ новомъ стилѣ.

По Em. Fellingery.

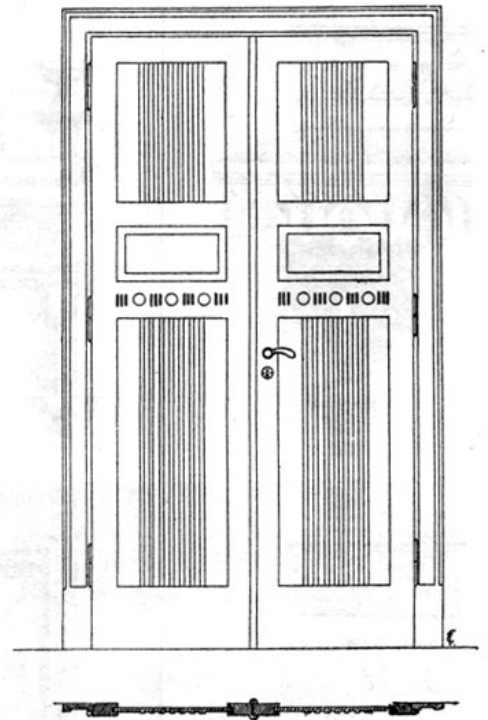

Столбъ навѣса.

Арх. Кузьминъ.

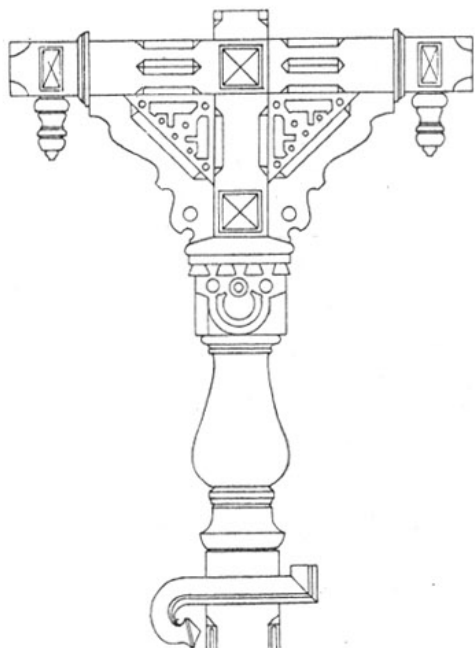

Колонна (театръ въ Павловскѣ).

Проф. Арх. Н. Л. Бенуа.



Деревянная колонна.

Арх. Minetti.

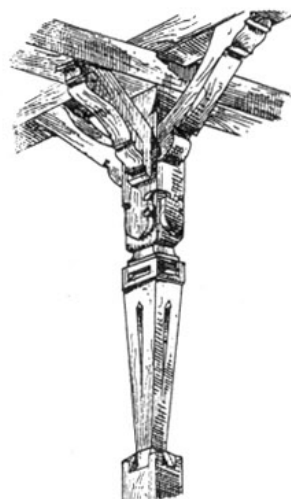

Деревянная колонна.

Арх. Кузьминъ.

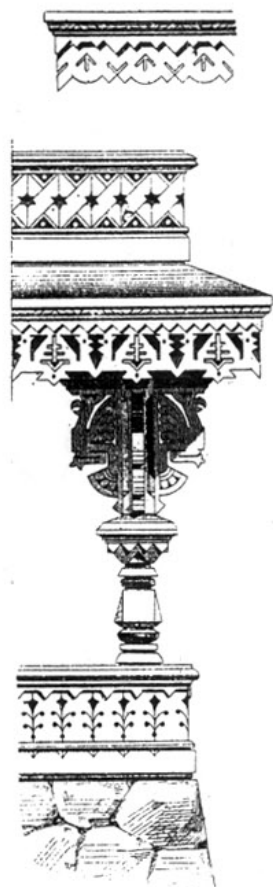

А. В. С. Деревянные столбы и колонны

по Bethke.

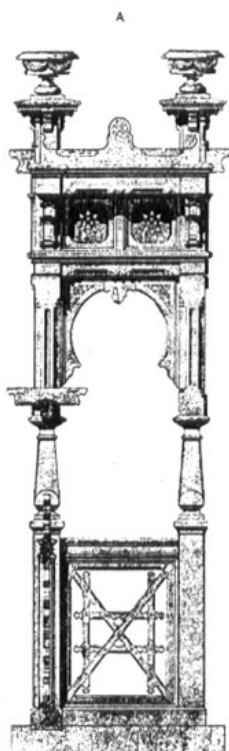

C

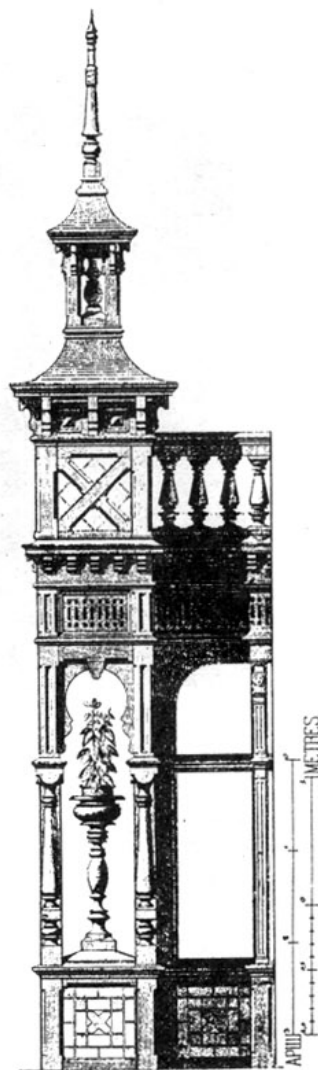

# ДЕРЕВЯННЫЕ СТОЛБЫ И КОЛОННЫ

Выст. въ Н. Новгородѣ 1896 г.  
Колонны подъѣзда Царскаго Павильона.

Арх. О. Виррихъ.



Дерев. столбы и колонны  
по Краuth'у и Meyer'у.

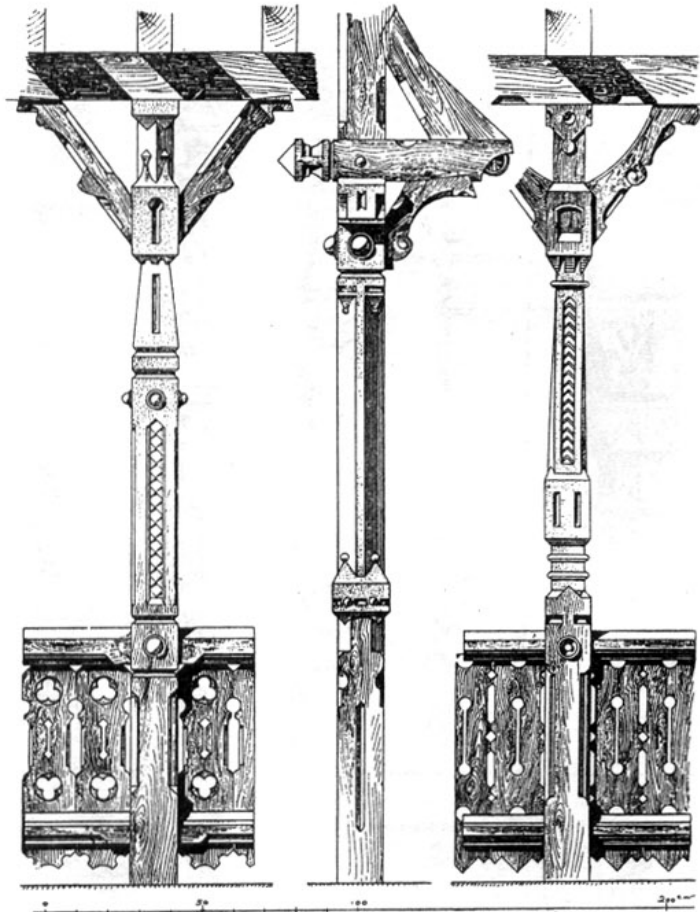

Дерев. столбы и колонны

по Краuth'у и Meyer'у.

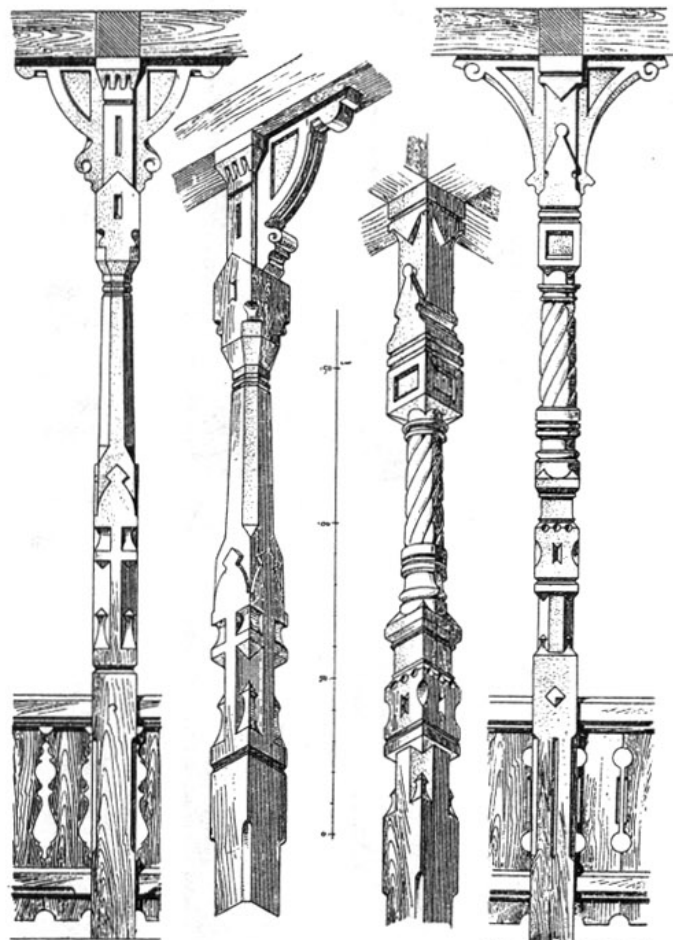
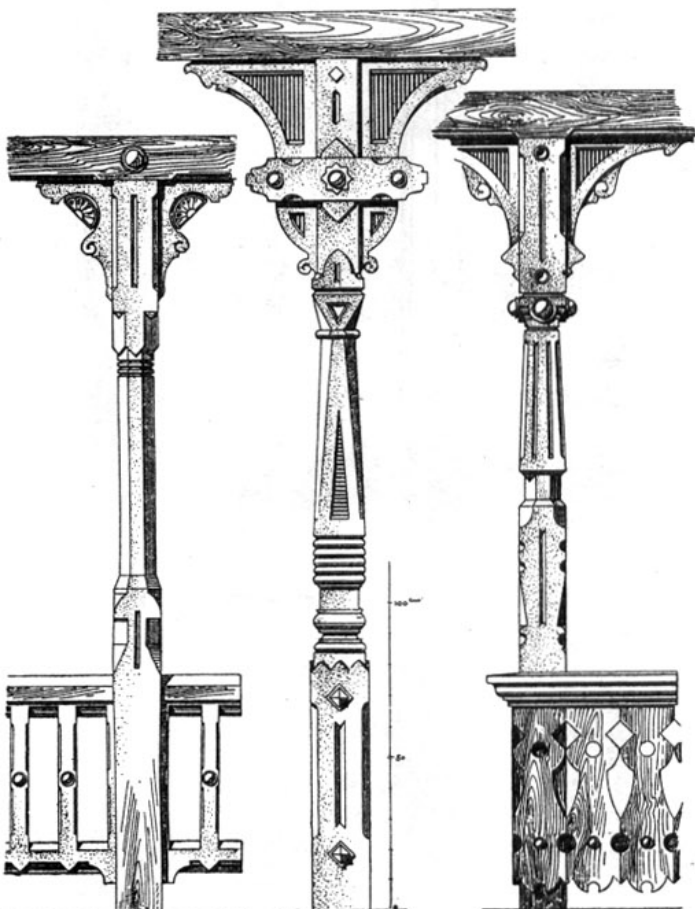



# ДЕРЕВЯННЫЕ СТОЛБЫ И КОЛОННЫ

Дерев. колонны и столбы (по Krauth'y и Meyer'y).

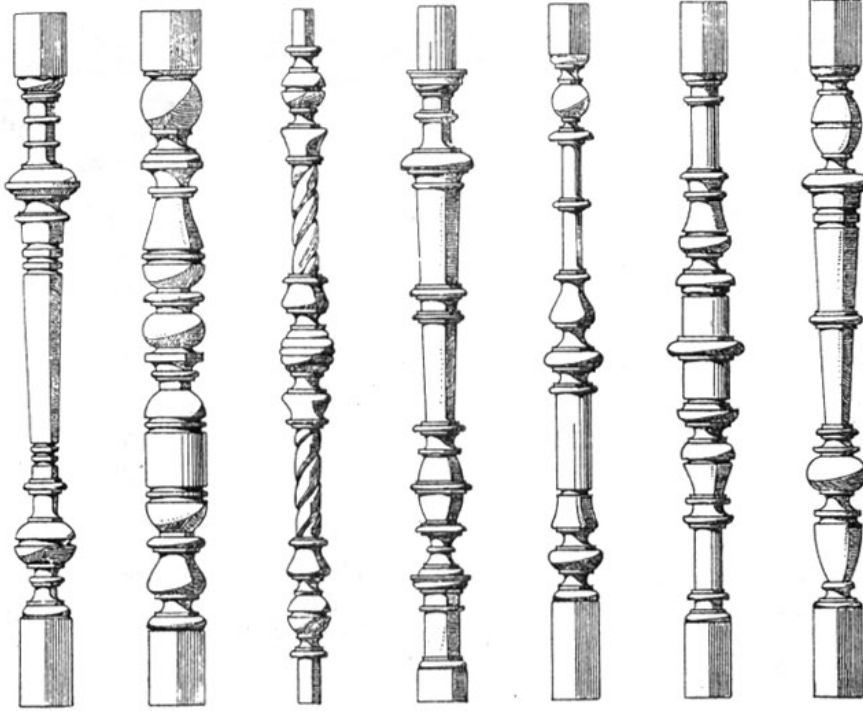

## КАМЕННЫЕ БАЛЮСТРАДЫ

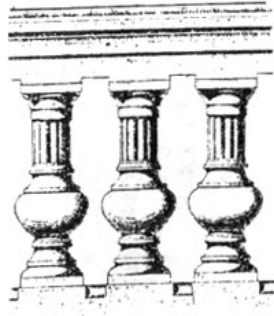

Théâtre du Chatelet.

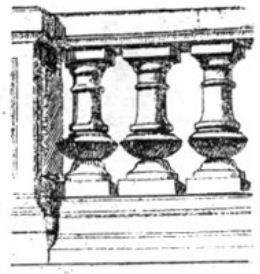

Арх. Тропюис (Парижъ).

Дерев. капитель.  
Павильонъ на выставкѣ  
въ Амстердамѣ 1883 г.).

Арх. Трар-Мейер.



Дерев. колонны и столбы (по В. Dorschfeldt'y).

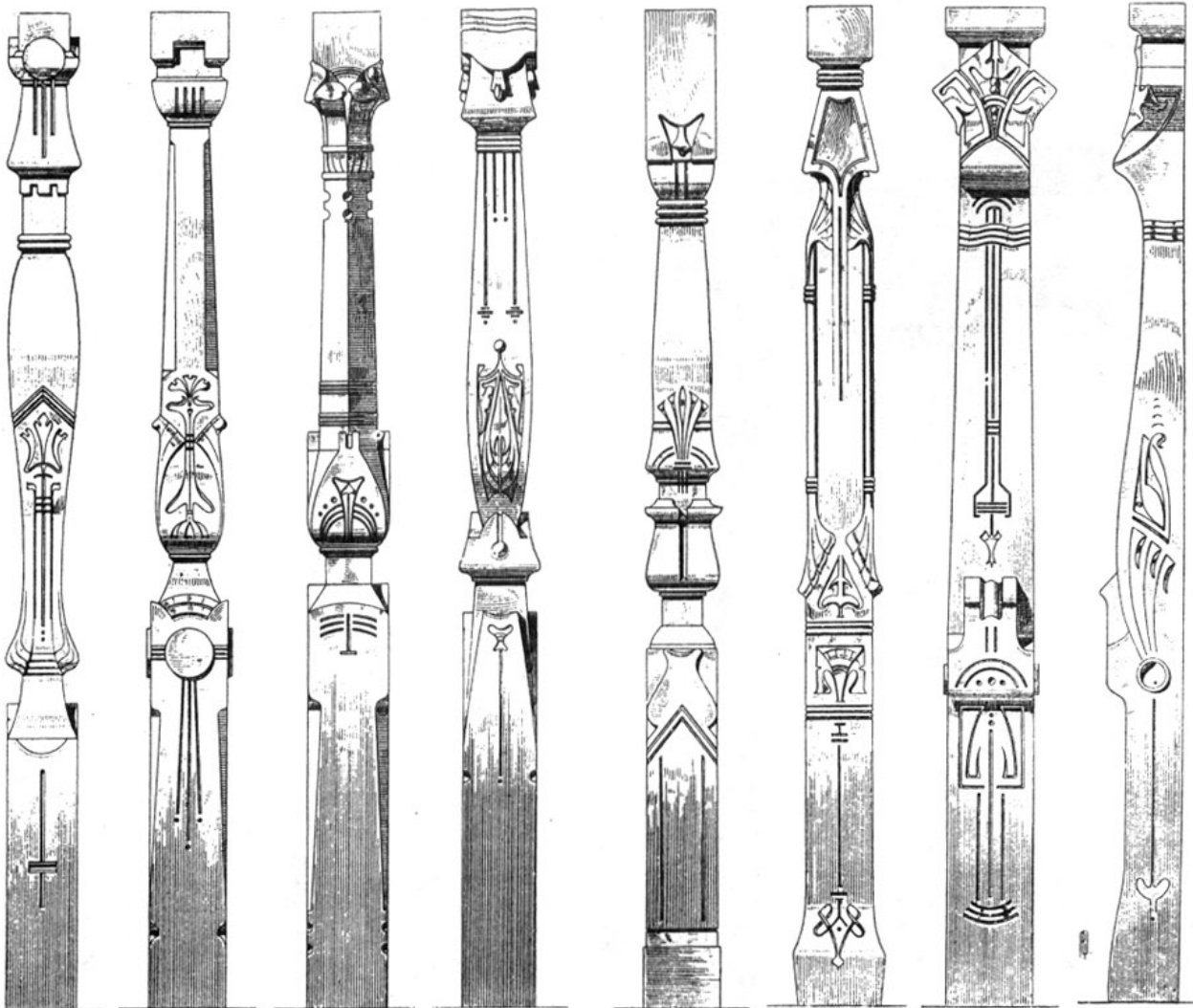

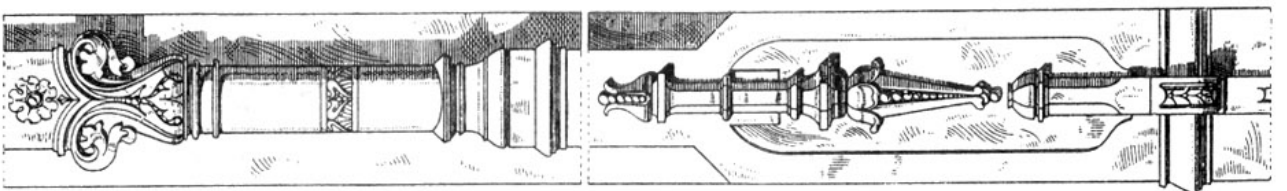
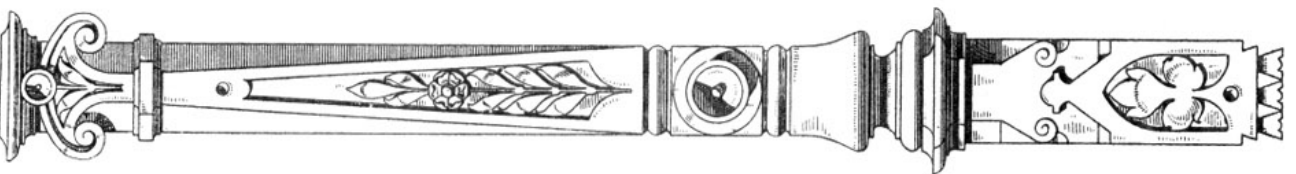
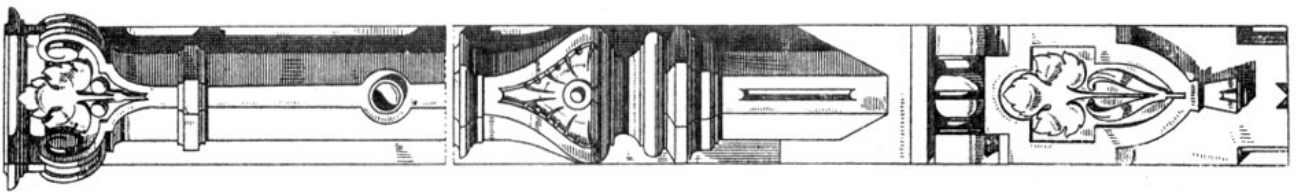
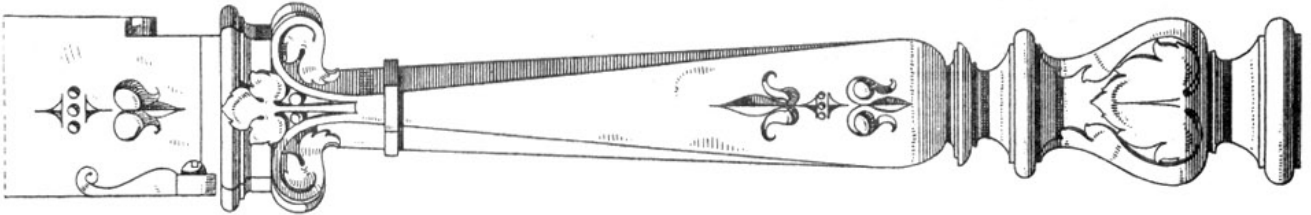
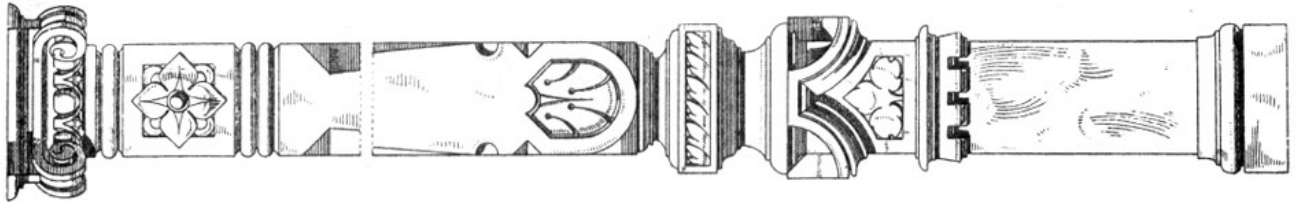
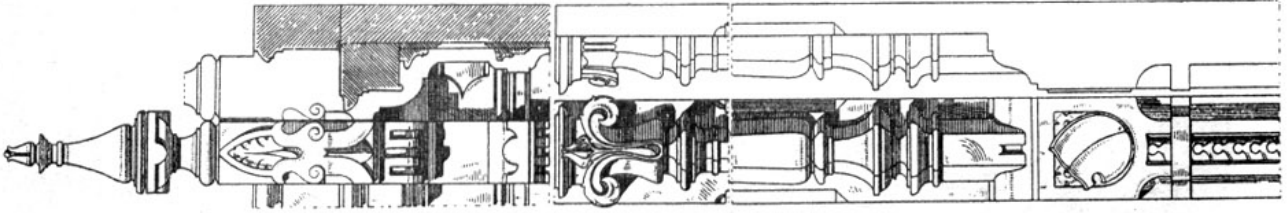
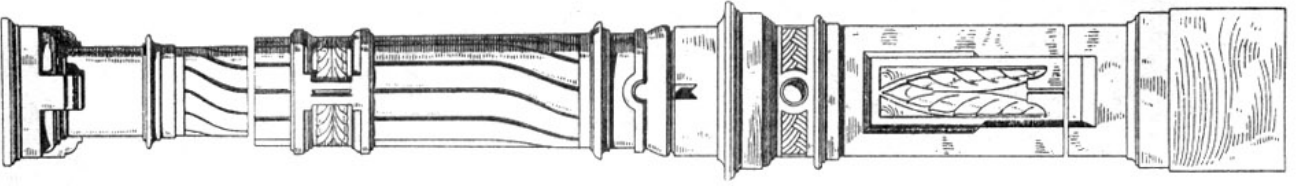
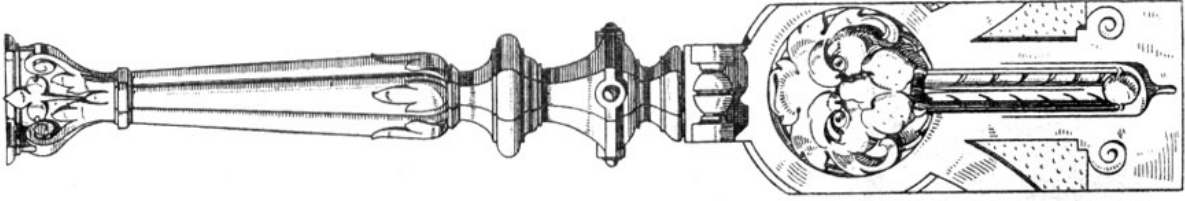
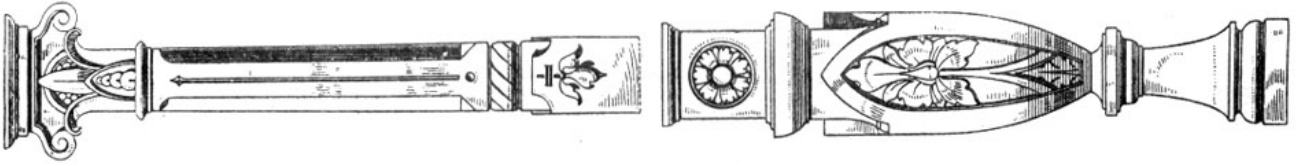

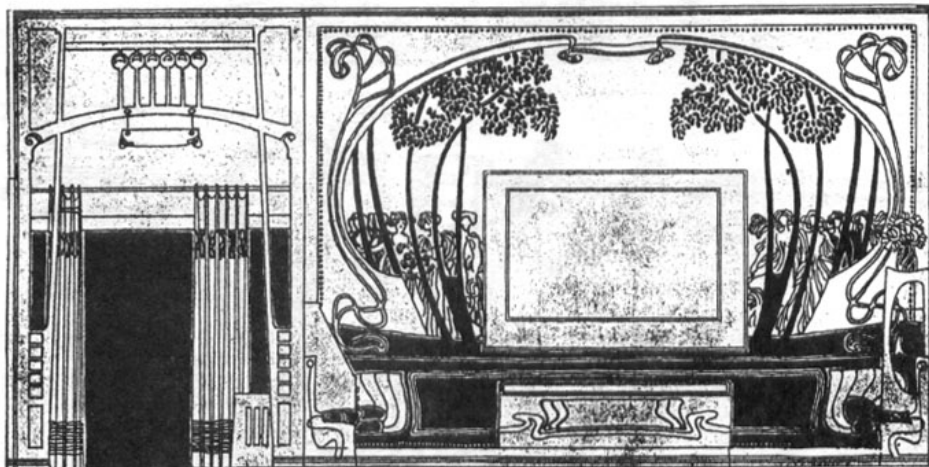

Вѣна. Kunstgewerbeschule. Мотивы декораціи стѣнъ

Арх. J. Hoffmann.

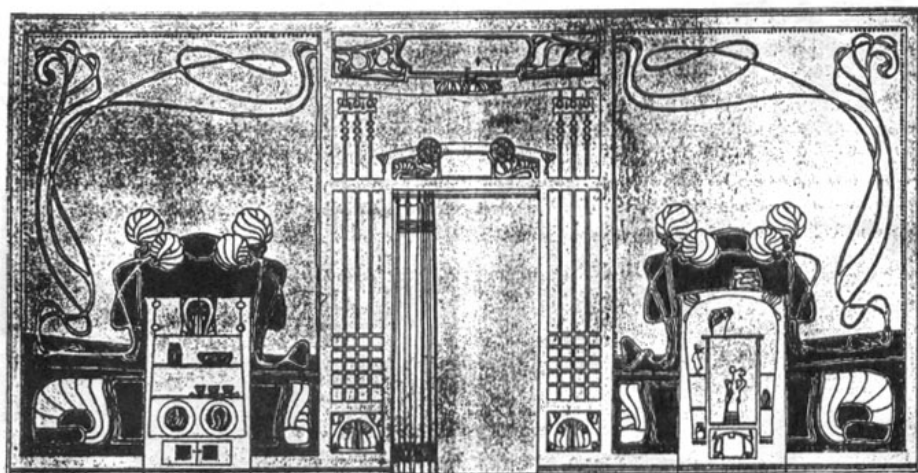

Вѣна. Kunstgewerbeschule. Мотивы декораціи стѣнъ.

Арх. J. Hoffmann.

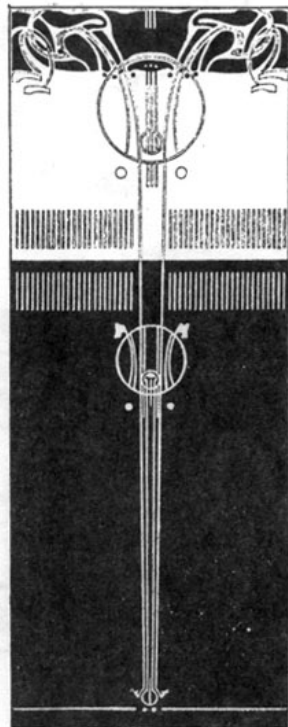

Живописная отдѣлка

стѣнъ спальни

частнаго дома въ Вѣнѣ

Арх. Trösch



Мотивы

декоративной отдѣлки

стѣнъ

зала ресторана.

Арх. L. Dufour



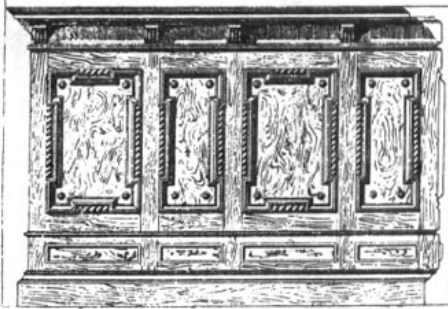

Деревянная панель

Арх. Гавел.

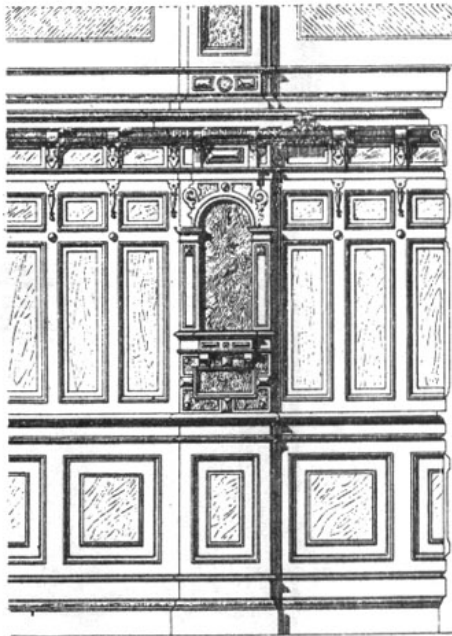
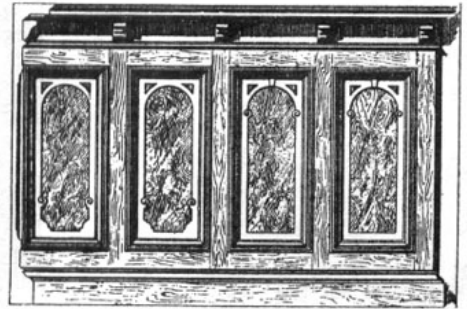

Деревянная панель

Арх. А. Huber.

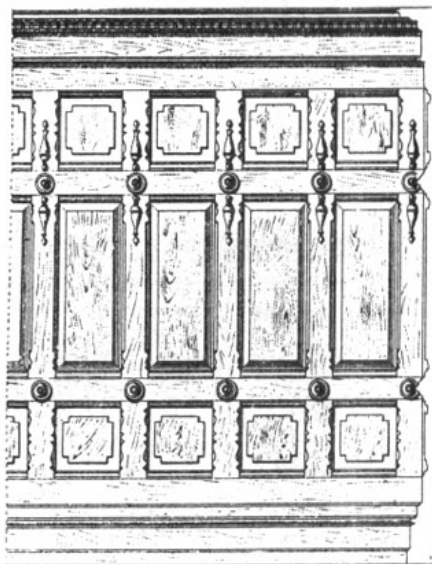
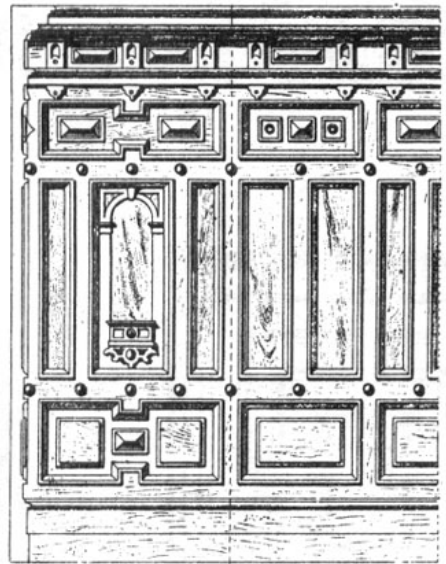

Деревянная панель.

Арх. Stegmüller & Ihne.

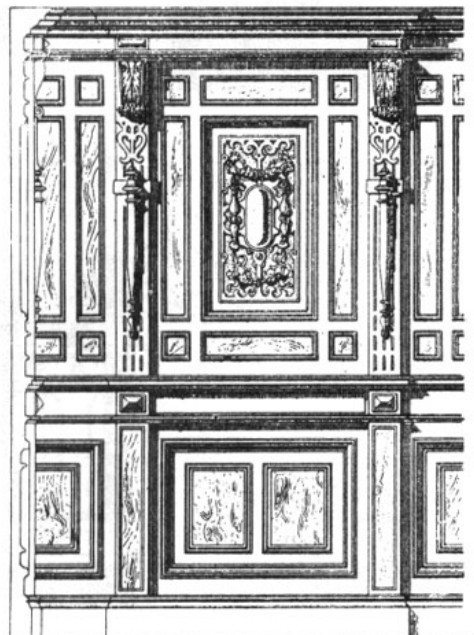



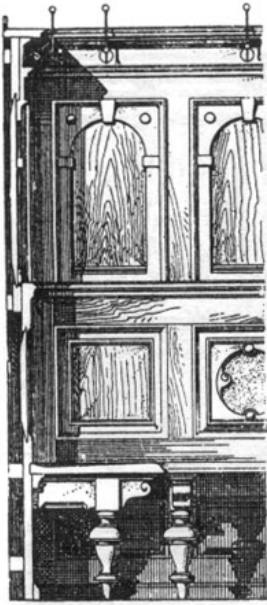

A.

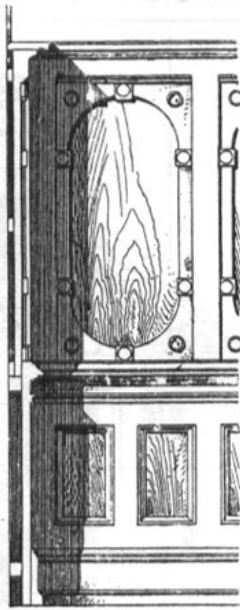

B.

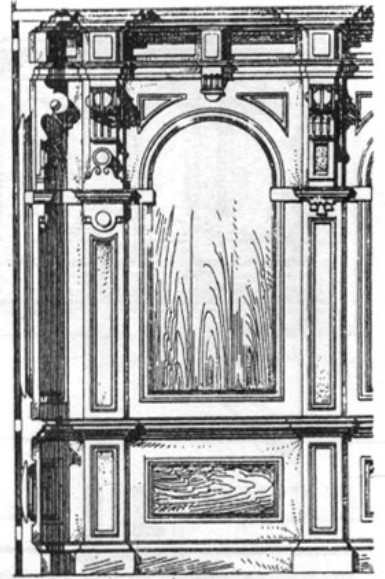

C.

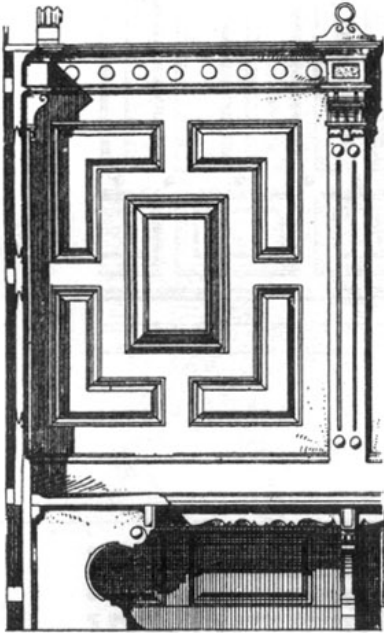

D.

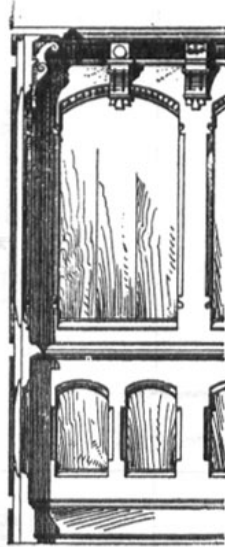

E.

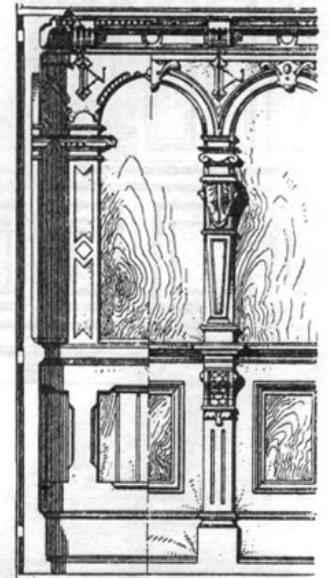

F.

A, B, C, D, E, F.

Мотивы деревянных панелей.

(по Krauth & Meyer).

H, I.

Деревянные панели с разными

филенками.

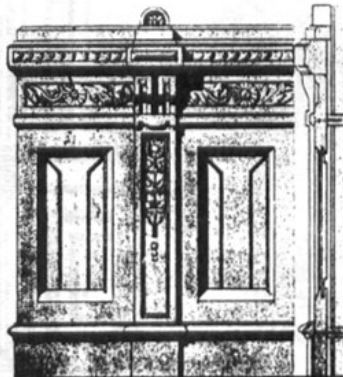

H.

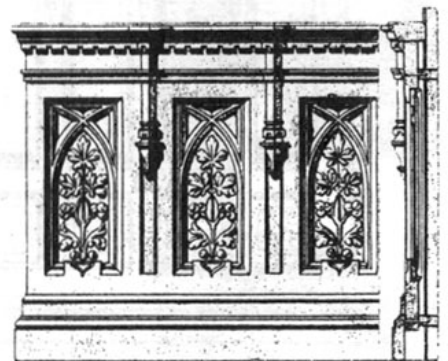

I.

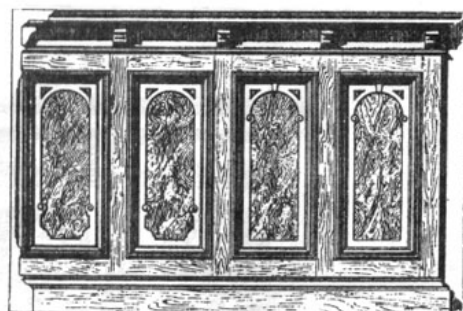
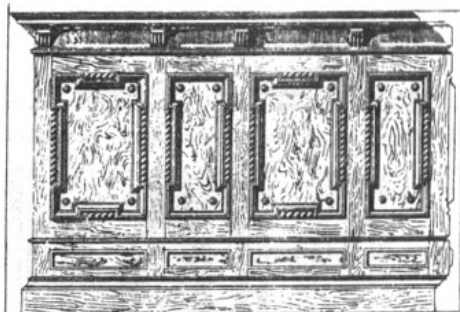

Деревянные панели.

Арх. Исвёл.

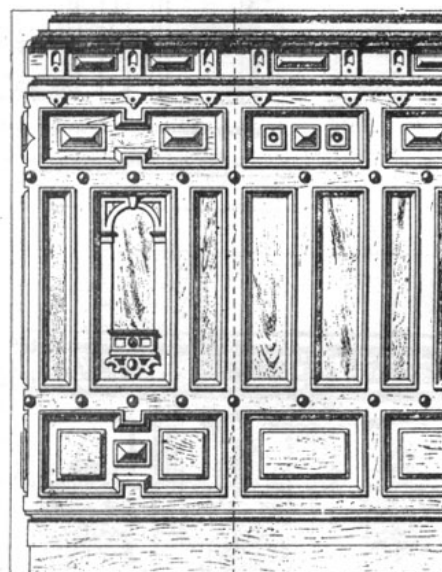
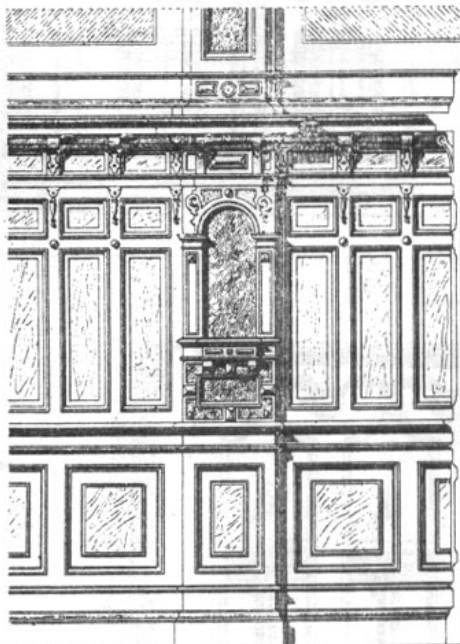

Деревянные панели.

Арх. А. Huber.

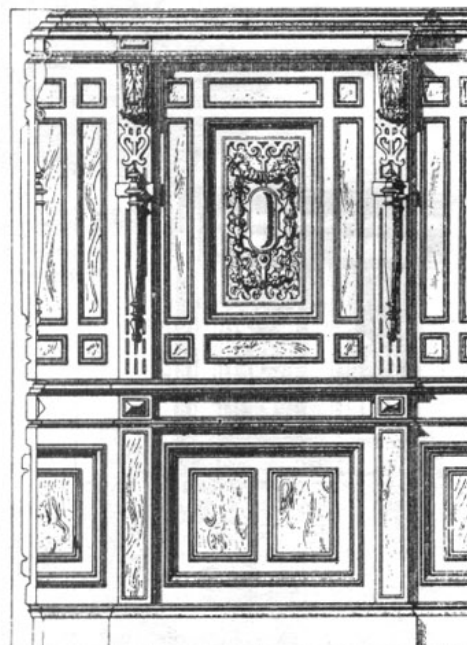
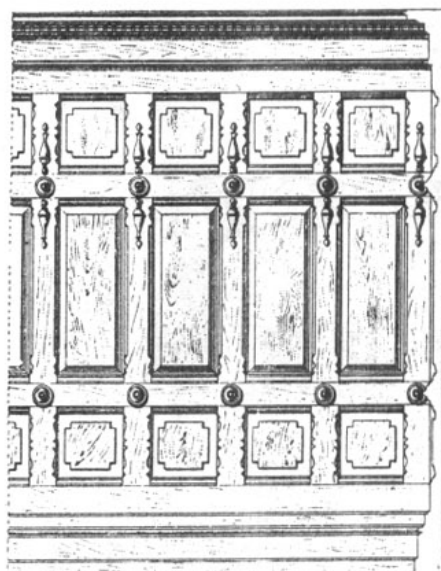

Деревянные панели.

Арх. Stegmüller & Ihne.

Деревянные  
панели  
с  
рѣзными  
филонками  
по  
R. Dorschfeldt'у.

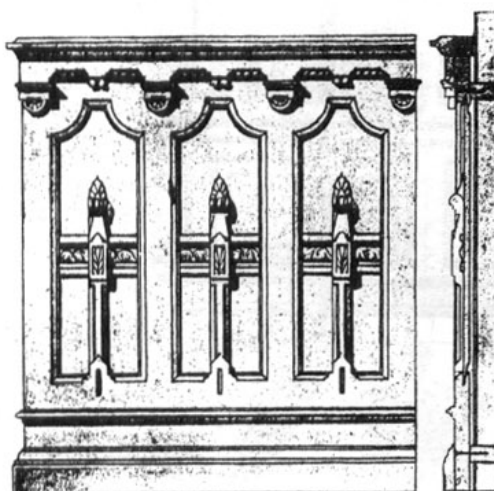
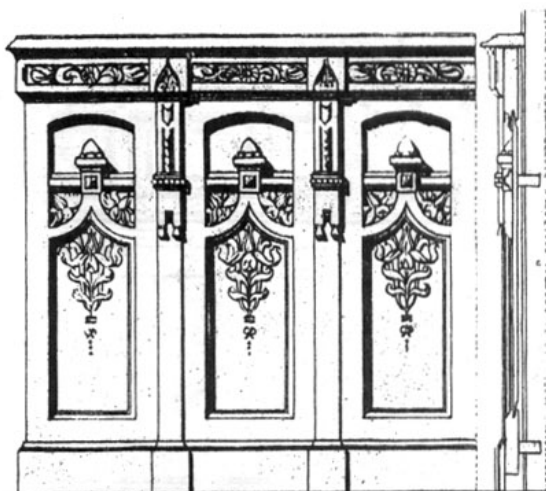
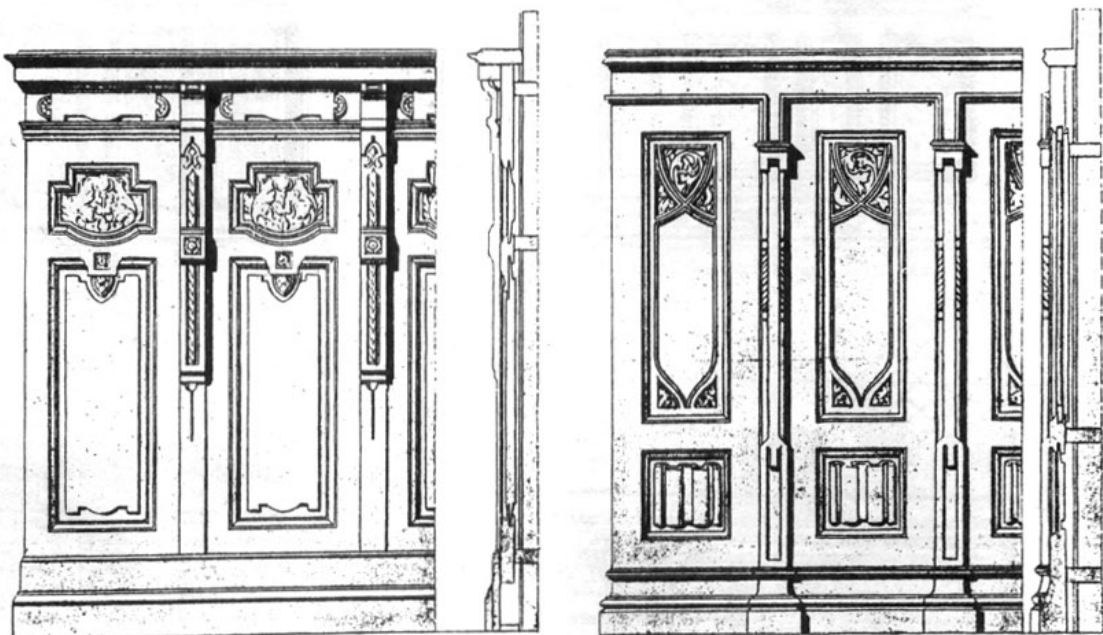

Деревянные  
панели  
с рѣзными  
филонками  
по  
R. Dorschfeldt'у.

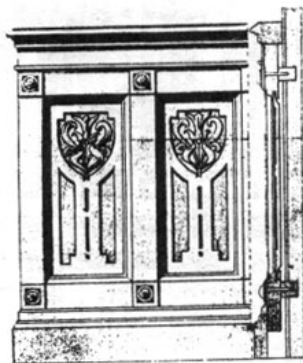

Деревянная панель с рѣзкой и обработка двери.

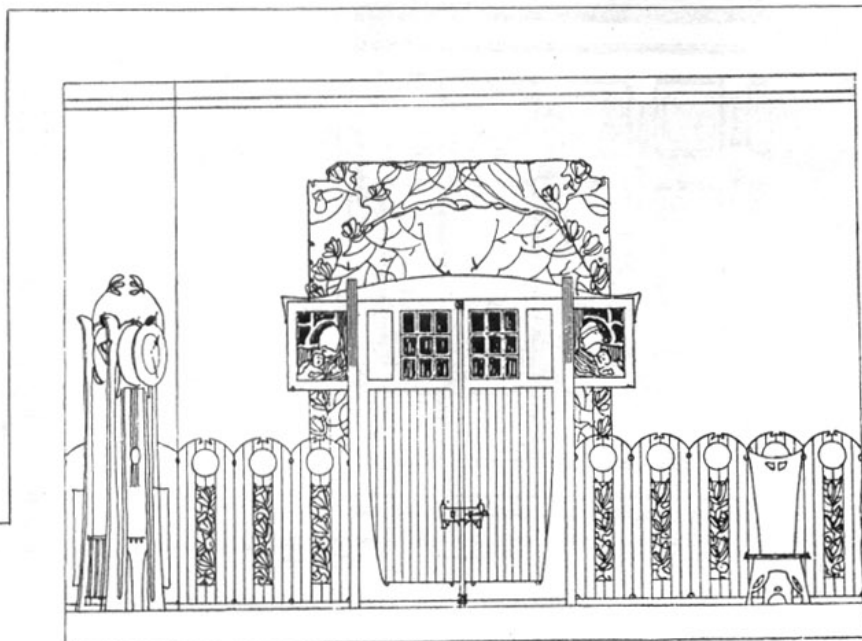

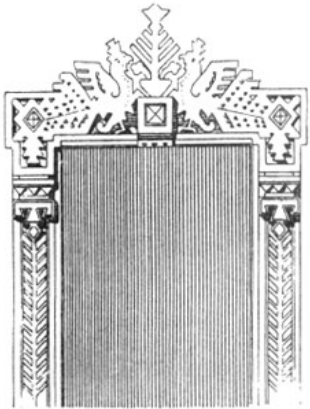
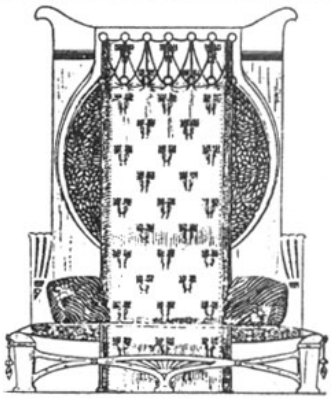

Убранство двери  
Арх. Ропель.

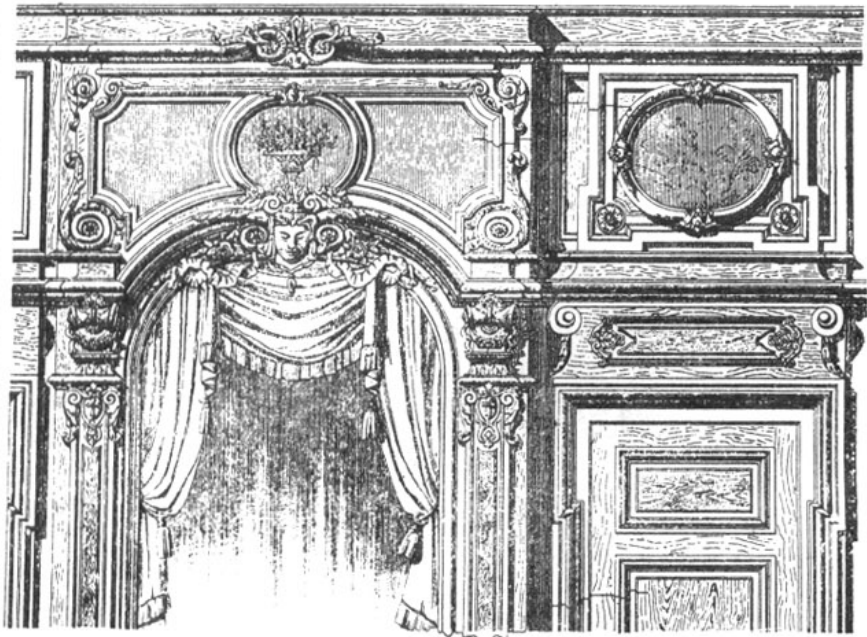

Отделка стѣны деревомъ и драпировки въ аркъ.

Арх. Martenot  
(Rennes).

Мотивы деревянныхъ панелей.  
(по Em. Fellingery).

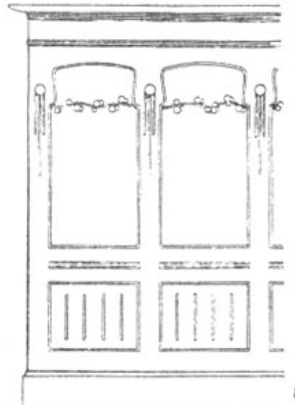
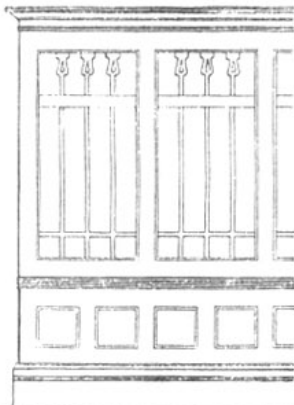
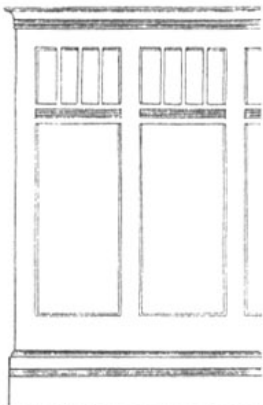
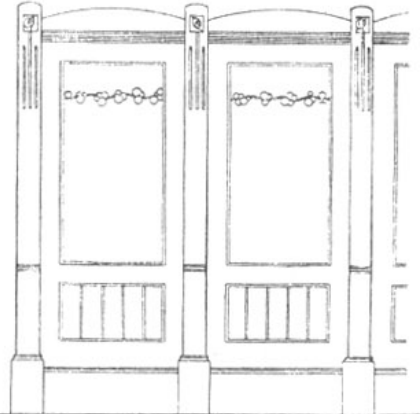
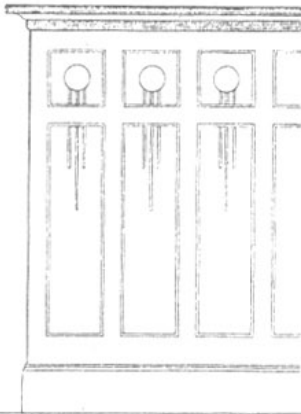
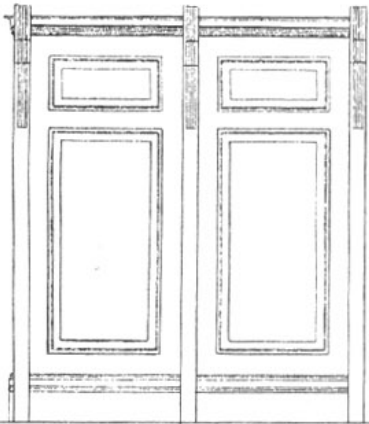



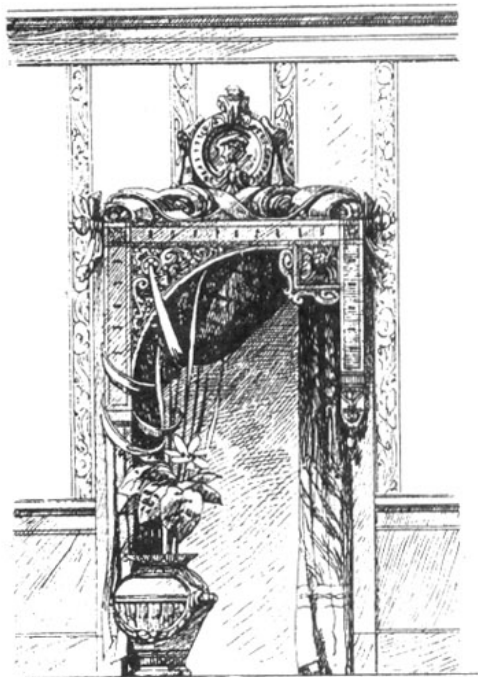

Дверь

Н. Вагнер.

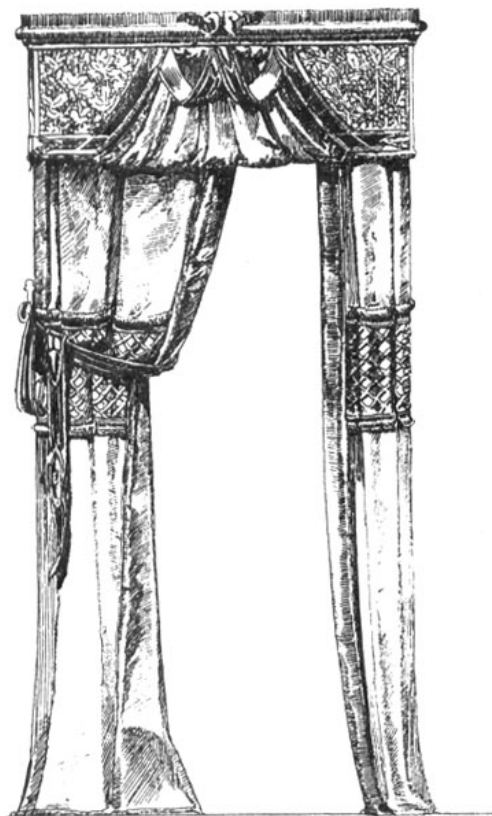

А.

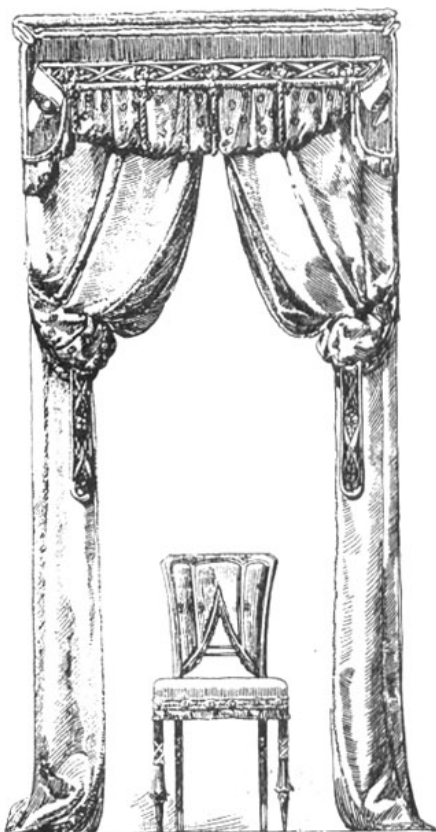

В.

А. В. С.  
Мотивы  
драпировокъ  
для  
дверей  
и  
оконъ  
...  
Арх.  
Негманн  
Верге  
(Берлинъ)



С.

Тремя выпусками серии «Детали»  
издательство «Стройиздат» продолжает  
начатое в 2000г. переиздание избранных  
таблиц из фундаментального труда  
**В.Г. Барановского**  
«Архитектурная энциклопедия XIX в.»

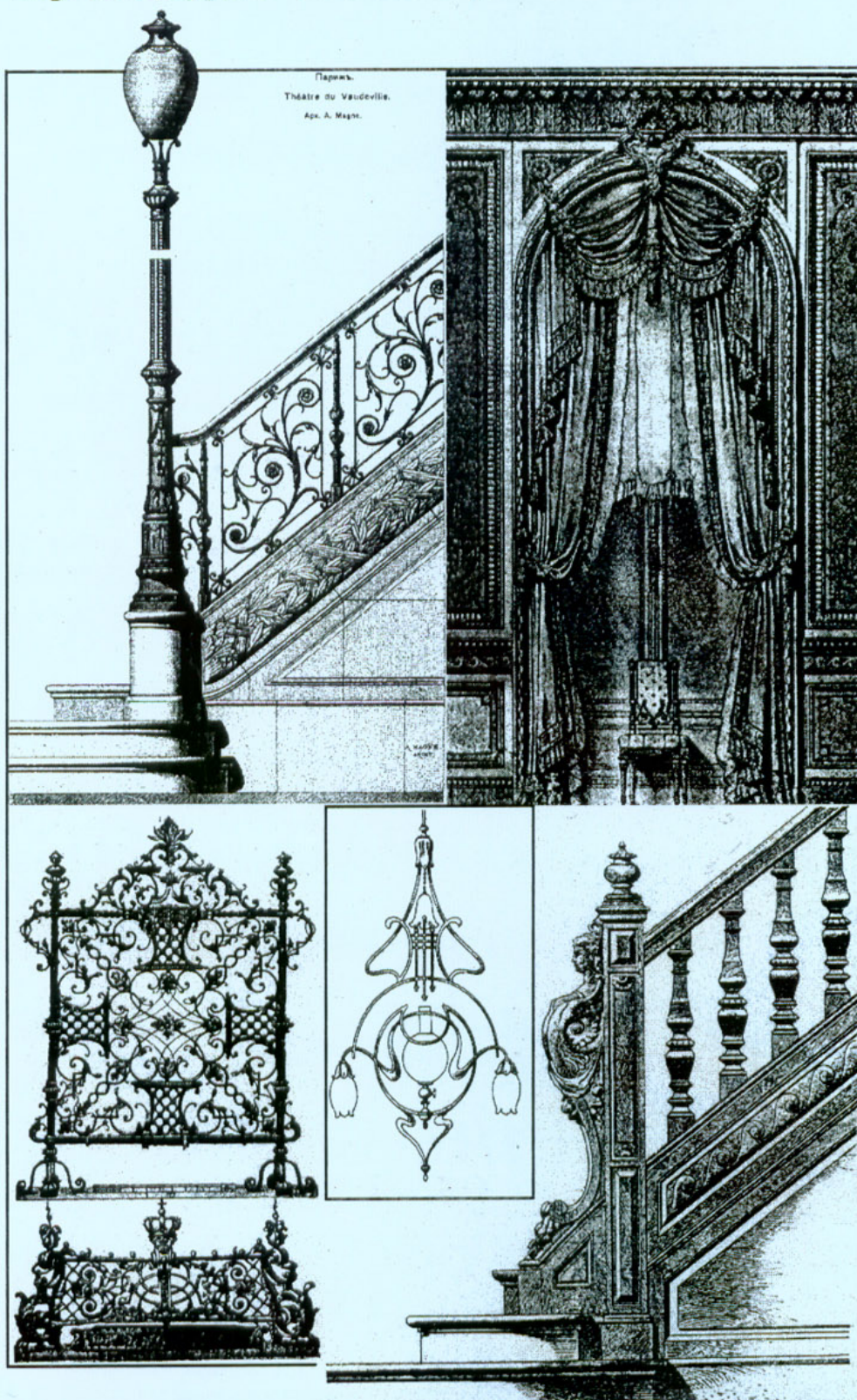

ISBN 5-274-02082-8



9 785274 020824 >

МОСКВА

СТРОЙИЗДАТ

2002